

TOWN OF NORTH HEMPSTEAD SOLID WASTE MANAGEMENT AUTHORITY



Request for Sealed Bids

**IMPORTANT: SEE “NOTICE TO BIDDERS” and “INSTRUCTIONS TO BIDDERS”
CLAUSES HEREIN BIDS MAY BE SENT TO THE ADDRESS LISTED BELOW ONLY**
(Fax and/or E-Mail Bid Submissions Will NOT Be Accepted)

<u>BID OPENING INFORMATION</u>	NAME OF BID: SWMA006R-2020- Chicago Pneumatic CPG 95 Generator, or an equivalent item
Date: December 1, 2020 Time: 11 AM	
INVITATION FOR BIDS NUMBER: SWMA006R-2020	Specification Reference: As Incorporated in the Invitation For Bids
CONTRACT PERIOD: One year from the date of award, with an option to extend for ninety (90) days in the sole discretion of the Town.	

The bid must be fully and properly executed by an authorized person.

By signing you certify your express authority to sign on behalf of yourself, your company, or other entity and full knowledge and acceptance of this INVITATION FOR BIDS, Authority General Conditions, and that all information provided is complete, true and accurate.

Legal Business Name of Company Bidding:	Bidder's Federal Tax Identification #: (Do Not Use SS#)
D/B/A - Doing Business As (if applicable):	
Street	City
State	Zip
If you are not bidding, place an "x" in the box and return this page only. <input type="checkbox"/> WE ARE UNABLE TO BID AT THIS TIME BECAUSE _____.	
Bidder's Signature: _____	Printed or Typed Name: _____
Title: _____	Date: _____
Phone: () - ext ()	E-mail Address: _____
Fax: () -	Company Web Site: _____

220 Plandome Road Manhasset NY 11030 • (516) 869-2403 (P) • (516) 869-2919(F)
Contracts@northhempsteadny.gov • www.northhempsteadny.gov

TOWN OF NORTH HEMPSTEAD SOLID WASTE MANAGEMENT AUTHORITY



Request for Sealed Bids

THIS BID CONTAINS THE FOLLOWING:

Notice to Bidders/Proposers
Instruction to Bidders/Proposers
Bid Specifications/Items List
General Conditions
Bidders' Qualifications Statement

(includes bidders statement, non-collusion statement, insurance forms)

Michael J. Kelly
Executive Director

Marshah-Reaff Barrett
Deputy Executive Director

IMPORTANT NOTE TO POTENTIAL BIDDERS: Receipt of these bid documents does not indicate that the Town of North Hempstead Solid Waste Management Authority (the "Authority") has pre-determined your company's qualifications to receive a contract award. Such determination will be made after the bid opening and will be based on our evaluation of your bid submission compared to the specific requirements and qualifications contained in these bid documents.

NOTICE TO BIDDERS

SEALED BIDS will be received by the Town of North Hempstead Solid Waste Management Authority at the Office of the Purchasing Division located on the lower level of Town Hall, 220 Plandome Road, Manhasset, New York 11030, **on the 1st day of December, 2020, at 11:00 AM**, at which time they will be opened and read and the Contract awarded as soon thereafter as practicable for:

SWMA 006R-2020- Chicago Pneumatic CPG 95 Generator

Bids may be mailed or delivered to the Purchasing Division, 220 Plandome Road, Manhasset, New York 11030, provided the Bid is actually received by the Purchasing Division prior to the time of public opening; or Bids may be delivered to the place of public opening (*i.e.*, the Office of the Purchasing Division) immediately prior to the time of public opening.

All Bids must be sealed and submitted in an envelope with the **Identification Label** provided in the Bid Documents affixed to the front of the envelope.

All BIDDERS MUST complete the required Bidder's Disclosure Statement, Non-Collusion Declaration, and must provide a copy of the required Statement of Financial Conditions, even if a Bidder is currently executing work for the Authority.

It is the policy of the Authority to encourage the participation of DBE and M/WBE; by bidding on this project, the contractor acknowledges its understanding and support of this policy and pledges to fully cooperate with the Authority in meeting the requirements as set forth in the bidding and contract documents.

The Authority reserves the absolute right to reject any and all Bids, and to waive any informalities therein.

The Authority will not accept Bids from, nor award a Contract to, anyone who cannot prove to the satisfaction of the Authority that the bidder has sufficient experience and/or is financially able and organized to successfully comply with the requirements set forth herein.

MICHAEL J. KELLY, EXECUTIVE DIRECTOR
TOWN OF NORTH HEMPSTEAD SOLID WASTE MANAGEMENT AUTHORITY

DATED: Port Washington, New York
Date: November 6, 2020

INSTRUCTIONS TO BIDDERS/PROPOSER'S

Please take Notice; for the purposes of this Request for Proposals ("RFP"), the term "Bid" and "Proposal" shall be interchangeable and shall be used synonymously.

ITB-1 BID/PROPOSAL PREPARATION

Prepare your bid/proposal on this form using indelible ink. One copy of the bid is required, unless otherwise specified herein.

ITB-2 BID DOCUMENTS

Failure to fully comply with any of the requirements or instructions contained within the bid document may constitute sufficient cause for rejection of the Bid/Proposal. Such rejections will be subject to the discretion of the Director of Purchasing.

Invitations for Bids will consist of the following documentary components:

- a. Notice to Bidders/Proposers
- b. Instructions to Bidders/Proposers
- c. General Conditions
- d. Standard Specifications (as defined in General Conditions)
- e. Proposal Form with Schedule 'A'
- f. Bidder's Qualifications Statement
- g. Addendum to Bid Documents

Invitations for Bids Involving Public Work or Building Services Pursuant to Articles 8 and 9 of the New York State Labor Law (as specified in the Proposal Form) **will also include the following documentary component:**

- a. New York State Department of Labor Wage Rate Schedule(s).

ITB - 3 EXAMINATION OF BID DOCUMENTS AND FAMILIARITY WITH SITE

BEFORE SUBMITTING A BID/PROPOSAL, ALL BIDDERS ARE ADVISED TO CAREFULLY EXAMINE THE BID DOCUMENTS; WHERE THE CONTRACT IS FOR PUBLIC WORK OR INSTALLATION THE BIDDER IS ADVISED TO VISIT THE SITE OF THE PROPOSED WORK TO BECOME COGNIZANT OF CONDITIONS AND LIMITATIONS ASSOCIATED WITH FULFILLING REQUIREMENTS OF THE BID DOCUMENTS, INCLUDING BUT NOT LIMITED TO PLANS AND SPECIFICATIONS.

Pleas of ignorance or misunderstanding of conditions that exist, or that may hereafter exist, or of conditions or difficulties that may be encountered in the execution of the work under this Contract, as a result of negligence by failing to make the necessary examinations and investigations as may be expected of a reasonably prudent Bidder, will NOT be accepted as grounds for any excuse on the part of a Contractor to fulfill in every respect all of the requirements of the Bid Documents, nor will such excuses be accepted by the Authority as a basis for any claims whatsoever for extra compensation, or for an extension of Contract completion time.

ITB-4 INTERPRETATION OF BID DOCUMENTS

If any prospective Bidder is unsure of, or has any reservations about, the precise and true meaning of any written or drawn material contained within any of the Bid Documents, or finds apparent discrepancies therein, or possible omissions therefrom, s/he shall promptly submit to the Director of Purchasing, a written request, fully describing the material in question, for an interpretation, explanation or revision thereto. The response to each request for clarification will be made only by an Addendum to the Bid Documents. Neither the Authority nor the Director of Purchasing may be held responsible or liable for any other explanations or interpretations of these Bid Documents.

ITB-5 ADDENDUM TO BID DOCUMENTS

Any Addendum issued during the bidding period shall become an integral part of the Bid Documents and shall be incorporated in the Bidder's Bid/Proposal. All Addendum shall be acknowledged in the Bidder's Bid/Proposal, by entering the title, date and signature of the person signing the Bid/Proposal.

ITB-6 MODIFICATIONS TO BID DOCUMENTS

Bids/Proposals shall not take exception to, or request modifications for, any item described in the Bid Documents. Oral Bids/Proposals will not be considered.

ITB-7 RIGHTS OF AUTHORITY BOARD

The Authority Board reserves the right to reject any and all Bids/Proposals and to waive any informalities in the Bids/Proposals received, and to accept the Bid/Proposal most favorable to the interests of the Authority, after all Bids/Proposals have been analyzed, checked and verified.

ITB-8 TAX EXEMPTION

The Owner is exempt from payment of Sales and Compensating Use Taxes of the State of New York and of cities and counties on all materials and supplies sold to the Authority pursuant to the provisions of this Contract. These taxes are not to be included in Bids/Proposals.

ITB-9 FORM OF BID/PROPOSAL

EACH BID/PROPOSAL MUST BE MADE ON THE "PROPOSAL FORM" ATTACHED HERETO AND SHALL REMAIN ATTACHED HERETO AS ONE OF THE BID DOCUMENTS AND SHALL BE SUBMITTED IN A SEALED ENVELOPE BEARING THE NAME OF THE BID, BID NUMBER, AND THE NAME OF THE BIDDER.

THE AUTHORITY HEREBY RESERVES THE ASBOLUTE RIGHT TO REJECT ANY BID/PROPOSAL THAT IS NOT MADE ON THE PROPOSAL FORM

ITB-10 DELIVERY OF BIDS/PROPOSALS

BIDS/PROPOSALS MUST BE DELIVERED BY THE TIME AND TO THE PLACE STIPULATED IN THE ADVERTISEMENT. IT IS THE SOLE RESPONSIBILITY OF THE BIDDER TO SEE THAT HIS BID/PROPOSAL IS RECEIVED IN THE PROPER TIME. ANY BIDS/PROPOSALS RECEIVED AFTER THE SCHEDULED CLOSING TIME FOR RECEIPT OF BIDS/PROPOSALS SHALL BE RETURNED TO THE BIDDER/PROPOSER UNOPENED.

ITB-11 CORRECTIONS TO BIDS/PROPOSALS

Erasures or other corrections in the Bid/Proposal must be initialized by the person signing the Bid/Proposal.

ITB-12 WITHDRAWAL OF BIDS/PROPOSALS

Any Bidder may withdraw his/her Bid/Proposal, either personally, or by telegraphic or written request, if such a request is received by the Purchasing Division at any time during normal working hours prior to the scheduled closing time for receipt of Bids/Proposals. If a Contract is not awarded within 45 calendar days after opening of the Bids, all Bids will be considered to have been rejected for cause, unless, at the Authority's request the low Bidder agrees to hold his Bid valid for an additional stipulated length of time.

ITB-13 MULTIPLE BID/PROPOSAL SUBMITTALS

Any person, firm or corporation will not be permitted to make more than one Bid/Proposal for the product or service. If a person is a partner, officer or director of more than one firm interested in bidding for the product or services, only one of the firms may submit a Bid/Proposal.

ITB-14 NON-COLLUSIVE BIDDING CERTIFICATION

In accordance with § 103-d of the General Municipal Law, by submission of this Bid/Proposal, each bidder and each person signing on behalf of any bidder certifies, and in the case of a joint bid each party thereto certifies as to its own organization, under penalty of perjury, that to the best of its knowledge and belief:

- (1) The prices in this bid/proposal have been arrived at independently without collusion, consultation, communication, or agreement, for the purpose of restricting competition, as to any matter relating to such prices with any other bidder/proposer or with any competitor;
- (2) Unless otherwise required by law, the prices which have been quoted in this bid/proposal have not been knowingly disclosed by the bidder/proposer and will not knowingly be disclosed by the bidder/proposer prior to opening, directly or indirectly, to any other bidder or to any competitor; and
- (3) No attempt has been made or will be made by the bidder/proposer to induce any other person, partnership or corporation to submit or not submit a bid for the purpose of restricting competition.

ITB-15 QUALIFICATIONS OF BIDDERS

A BIDDER'S QUALIFICATIONS STATEMENT IS REQUIRED. The forms attached hereto indicate all the information required. Each Bidder/Proposer shall be responsible for submitting his current Disclosure Statement with his Bid/Proposal. The Authority retains the right to investigate, verify the information submitted in the Disclosure Statement, and interview all bidders prior to award of the Contract. THE AUTHORITY HEREBY RESERVES THE ASBOLUTE RIGHT TO REJECT ANY BID/PROPOSAL THAT DOES NOT INLCUDE A DISCLOSURE STATEMENT.

ITB- 16 IDENTIFICATION LABEL

To properly expedite the receipt and processing of bids submitted, the following "Identification Label" must be affixed to the outer envelope of the sealed bid. Bids shall be delivered by U.S. Mail, public carrier (e.g. UPS, FedEx), or by hand. THE AUTHORITY HEREBY RESERVES THE ASBOLUTE RIGHT TO REJECT ANY BID/PROPOPOSAL THAT DOES NOT CONFORM TO THIS SECTION.

SEALED BID ENCLOSED
Town of North Hempstead
Department of Finance Purchasing
Division

Bidder's Name: _____

Bid Number: _____

Bid Name: _____

Due Date: _____

Bid Specifications

The Town of North Hempstead Solid Waste Management Authority (the “Authority”) is seeking qualified contractors to bid on a Chicago Pneumatic CPG 95 Generator, Trailer Mounted, or an equal or better product.

This is a requirements contract. There are no minimum mandatory purchases. The Authority reserves the right to award in whole or in parts or not at all, whichever is in the best interest of the Authority. The Authority reserves the right to award future contracts/purchase orders to the next low bidder in the event of default or cancellation of a previously awarded Contract/purchase order.

Service Requirements

The Authority is seeking proposers to bid on a Chicago Pneumatic CPG 95 Generator, or an equal or better product. The Authority is seeking to purchase a trailer-mounted generator. Specifications are attached hereto as Exhibit A.

Term and Award

Bid will be valid for one (1) year from the date of award. The Authority may extend any time period by a term not to exceed ninety (90) days in its discretion.

Bidding and Claims Payment

Please use the following Bid Proposal Form to submit bid. Please ensure that the pricing is all inclusive, including delivery costs and standard warranty costs. The Town will not pay for delivery.

Specifications for the items listed can be found in Exhibit A at the end of this document. If bidding an alternative item, please include detailed specifications. The Town reserves the right to request that vendor make product available for inspection. The determination of whether an item is equal or better is solely within the purview of the Town.

Use by Town

The Town of North Hempstead reserves the right to use this contract from time to time, as needed. The same terms and conditions will apply.

Bid Proposal Form

Name, Address, Phone Number, email and Contact Person for Proposer

Please bid price per unit. Prices must be all inclusive and include delivery.

Item	DESCRIPTION	UNIT PRICE	
1	Chicago Pneumatic CPG 95 Generator, Trailer Mounted , or an equal or better product		
	OPTIONS	UNIT PRICE	
2	Battery Charger		
	Battery (800CCA Optima, Spiralcell AGM, Redtop)		
3	Coolant Heater		
4	Spare Tire		
5	Tool Box		
6	Rear Stabilizer Jacks		
7	External Fuel Connections		
	WARRANTY	Length	Price
8	Length of Standard Warranty (included in purchase price)		Included
9	Extended Warranty		

GENERAL CONDITIONS

1. **APPLICABILITY** The terms and conditions set forth in this section entitled General Conditions are expressly incorporated in and applicable to the resulting procurement contracts let by the Town of North Hempstead Solid Waste management Authority where incorporated by reference in its Bid Documents. Captions are intended as descriptive and are not intended to limit or otherwise restrict the terms and conditions set forth herein.

2. **GOVERNING LAW** This procurement, the resulting contract and any purchase orders issued hereunder shall be governed by the laws of the State of New York except where the Federal supremacy clause requires otherwise, and actions or proceedings arising from the contract shall be heard in a court of competent jurisdiction in the State of New York.

3. **NO ARBITRATION** Disputes involving this procurement, the resulting contract, including the breach or alleged breach thereof, and any purchase orders issued hereunder may not be submitted to binding arbitration (except where statutorily authorized), but must, instead, be heard in a court of competent jurisdiction of the State of New York.

4. **ETHICS COMPLIANCE** All Bidders/Contractors and their employees must comply with the requirements of Section 16A of the Code of the Town of North Hempstead, other New York State codes, rules, regulations and executive orders establishing ethical standards for the conduct of business with New York State. In signing the Bid, Bidder certifies full compliance with those provisions for any present or future dealings, transactions, sales, contracts, services, offers, relationships, etc., involving the Town of North Hempstead Solid Waste Management Authority and/or its employees. Failure to comply with those provisions may result in disqualification from the Bidding process, termination of contract, and/or other civil or criminal proceedings as required by law.

5. **CONFLICT OF TERMS** Unless otherwise set forth in the procurement or contract documents, conflicts among documents shall be resolved in the following order of precedence:

(A) Contract and other writing(s) setting forth the final agreements, clarifications and terms between the Bid Documents and Contractor's Bid. In the latter circumstance, clarifications must specifically note in writing what was offered by the Contractor and what was accepted by the Authority of North Hempstead. If not, such clarifications shall be considered last in the order of precedence under this paragraph.

- (1) General Conditions.
- (2) Bid Specifications.
- (3) Bid Documents.
- (4) Contractor's Bid/Proposal.

6. **DEFINITIONS**

AUTHORITY shall mean the Town of North Hempstead Solid Waste Management Authority, located in Nassau County, New York.

AUTHORITY BOARD shall mean the board members of the Town of north Hempstead Solid Waste Management, Nassau County, New York.

AWARD is the decision of the Authority to accept the Bid/Proposal of the lowest responsive, responsible Bidder/Contractor for the procurement included in these Bid Documents. An award letter will be issued by the Authority informing the Contractor that its bid was accepted.

BID DOCUMENTS Writings by the Authority setting forth the scope, terms, conditions and technical specifications for procurement. Such writings typically include, but are not limited to: Invitation for Bids (IFB), Request for Quotation (RFQ), Request for Proposals (RFP), addenda or amendments thereto, and terms and conditions contained therein or incorporated by reference.

BID OR PROPOSAL An offer or proposal submitted by a Bidder to furnish a described product or a solution, perform services or means of achieving a practical end, at a stated price for the stated Contract term. For the purpose of this Request for Proposal, the term "Bid" and "Proposal" shall be interchangeable and shall be used synonymously. As required by the Bid Documents, the Bid or proposal may be subject to modification through the solicitation by the Authority of best and final offers during the evaluation process prior to recommendation for award of the Contract.

BIDDER/OFFERER Any individual or other legal entity (including but not limited to sole proprietor, partnership, limited liability company, firm or corporation) which submits a Bid in response to a solicitation. The term Bidder shall also include the term "proposer" or "offeror." In the case of negotiated Contracts, "Bidder" shall refer to the "Contractor."

BID SPECIFICATION A written description drafted by the Authority setting forth the specific terms of the intended procurement, which may include: physical or functional characteristics, the nature of a commodity or construction item, any description of the work to be performed, Products to be provided, the necessary qualifications of the Bidder, the capacity and capability of the Bidder to successfully carry out the proposed Contract, or the process for achieving specific results and/or anticipated outcomes or any other requirement necessary to perform work.

CONTRACT The writing(s) which contain the agreement of the Authority and the Bidder/Contractor setting forth the total legal obligation between the parties as determined by applicable rules of law.

CONTRACT DOCUMENTS consist of the Contract or Purchase Order made between the Authority and the Bidder/Contractor (hereinafter the Agreement), General Conditions, Bid Specifications, Bid Documents, including among others the Notice to Bidders, Instructions to Bidders, any Schedule of Bid Prices, any Addendum to Bid Documents issued prior to execution of the Contract, Bidder's Qualification Statement, Bidder's Proposal (including non-collusive bidding statement), contract or purchase order(s) issued, Insurance and Indemnity Certification, Bid Bond(s) (where required), Performance Bond(s), Materials & Labor Bond(s) (where required), or Maintenance Bond (where required), any New York State Department of Labor Wage Rate Schedule(s) (for public work or building services as defined by Articles 8 and 9 of the New York State Labor Law),

any additional Documentation required for contract execution, any supplemental agreements issued during the course of the Contract, and/or Modifications issued after execution of the Contract. A Modification is: (1) a written amendment to the Contract signed by both parties including but not limited to work change orders or changes to purchase orders.

COMPROLLER Comptroller of the Town of North Hempstead.

CONTRACTOR Any successful Bidder(s) to whom a Contract has been awarded by the Authority.

DIRECTOR Director of Purchasing or his/her authorized representative.

DOCUMENTATION The complete set of manuals (e.g., user, installation, instruction or diagnostic manuals) in either hard or electronic copy, which are necessary to enable the Authority to properly test, install, operate and enjoy full use of the Product.

MULTIPLE AWARD A determination and award of a Contract in the discretion of the Director to more than one responsive and responsible Bidder who meets the requirements of a specification, where the multiple award is made on the grounds set forth in the Bid Document in order to satisfy multiple factors and needs of the Authority (e.g., complexity of items, various manufacturers, differences in performance required to accomplish or produce required end results, production and distribution facilities, price, compliance with delivery requirements, geographic location or other pertinent factors).

PRODUCT A deliverable under any Bid or Contract which may include commodities, services and/or technology, including software.

PURCHASING DIVISION shall mean the Authority of North Hempstead, Department of Finance, Purchasing Division.

PURCHASE ORDER The Authority's fiscal form or format that is used when making a purchase (e.g., Claim Form, formal written Purchase Order, electronic Purchase Order, or other authorized instrument).

SINGLE SOURCE A procurement where two or more Bidders can supply the required Product, and the Director may award the contract to one Bidder over the other.

SITE The location (street address) where Product will be executed or services delivered.

SOLE SOURCE A procurement where only one Bidder is capable of supplying the required Product.

SUBCONTRACTOR Any individual or other legal entity, (including but not limited to sole proprietor, partnership, Limited Liability Company, firm or corporation) that has entered into a contract, express or implied, for the performance of a portion of a Contract with a Contractor.

TOWN shall mean the Town of North Hempstead, Nassau County, New York.

TOWN ATTORNEY Town Attorney of the Town of North Hempstead who also functions as Counsel to the Authority.

BID SUBMISSION

7. **BID OPENING** Bids may, as applicable, be opened publicly. The Director reserves the right at any time to postpone or cancel a scheduled Bid opening.

8. **BID/PROPOSAL SUBMISSION** All Bids/Proposals are to be packaged, sealed and submitted to the location stated in the Bid/Proposal Specifications. Bidders/Proposers are solely responsible for timely delivery of their Bids/Proposals to the location set forth in the Bid Specifications prior to the stated Bid opening date/time.

A Bid/Proposal return envelope, if provided with the Bid Specifications, should be used with the Bid/Proposal sealed inside. If the Bid/Proposal response does not fit into the envelope, the Bid/Proposal envelope should be attached to the outside of the sealed box or package with the Bid/Proposal inside. If using a commercial delivery company that requires use of their shipping package or envelope, Bidder's/Proposer's sealed Bid, labeled as detailed below, should be placed within the shipper's sealed envelope to ensure that the Bid is not prematurely opened.

All Bids/Proposals must have a label on the outside of the package or shipping container outlining the following information:

"BID/PROPOSAL ENCLOSED (bold print, all capitals)

- Bid/Proposal Name
- Bid/Proposal Number
- Bid/Proposal Submission date and time"

In the event that a Bidder/Proposer fails to provide such information on the return Bid/Proposal envelope or shipping material, the Authority reserves the right to open the shipping package or envelope to determine the proper Bid/Proposal number or Bid/Proposal Name, and the date and time of Bid opening. Bidder/Proposer shall have no claim against the Authority arising from such opening and such opening shall not affect the validity of the Bid/Proposal or the procurement. Notwithstanding the Authority's right to open a Bid/Proposal to ascertain the foregoing information, Bidder/Proposer assumes all risk of late delivery associated with the Bid/Proposer not being identified, packaged or labeled in accordance with the

foregoing requirements.

All Bids/Proposals must be signed by a person authorized to commit the Bidder/Proposer to the terms of the Bid Documents and the content of the Bid (offer).

9. **LATE BIDS/PROPOSALS** For purposes of Bid openings held and conducted by the Purchasing Division, a Bid must be received in such place as may be designated in the Bid Documents or if no place is specified to the Town of North Hempstead, Purchasing Division, 220 Plandome Road, Manhasset, New York 11030, at or before the date and time established in the Bid Specifications for the Bid opening.

Any Bid received at the specified location after the time specified will be considered a late Bid. A late Bid shall not be considered for award unless: (i) no timely Bids meeting the requirements of the Bid Documents are received or, (ii) in the case of a multiple award, an insufficient number of timely Bids were received to satisfy the multiple award; and acceptance of the late Bid is in the best interests of the Authority. Delays in United States mail deliveries or any other means of transmittal, including couriers or agents of the Authority shall not excuse late Bid submissions. Similar types of delays, including but not limited to, bad weather or security procedures for parking and building admittance shall not excuse late Bid submissions. Determinations relative to Bid timeliness shall be at the sole discretion of the Director.

10. **BID/PROPOSAL CONTENTS** Bids/Proposals must be complete and legible. All Bids/proposals must be signed. All information required by the Bid Specifications must be supplied by the Bidder/Proposer on the forms or in the format specified. No alteration, erasure or addition is to be made to the Bid Documents. Changes may be ignored by the Director or may be grounds for rejection of the Bid. Changes, corrections and/or use of white-out in the Bid or Bidder's/Proposer's response portion of the Bid Document must be initialed by an authorized representative of the Bidder/Proposer. Bidders/Proposers are cautioned to verify their Bids/Proposals before submission, as amendments to Bids or requests for withdrawal of Bids/Proposals received by the Director after the time specified for the Bid opening/date of submission of RFP, may not be considered.

11. **EXTRANEOUS TERMS** Bids/Proposals must conform to the terms set forth in the Bid Documents, as extraneous terms or material deviations (including additional, inconsistent, conflicting or alternative terms) may render the Bid/Proposal non-responsive and may result in rejection of the Bid/Proposal.

Extraneous term(s) submitted on standard, pre-printed forms (including but not limited to: product literature, order forms, license agreements, contracts or other documents) that are attached or referenced with submissions shall not be considered part of the Bid or resulting Contract, but shall be deemed included for informational or promotional purposes only.

No extraneous term(s), whether or not deemed "material," shall be incorporated into a Contract or Purchase Order unless the Director expressly accepts each such term(s) in writing. Acceptance and/or processing of the Bid shall not constitute such written acceptance of Extraneous Term(s).

12. **CONFIDENTIAL/TRADE SECRET MATERIALS** Contractor confidential trade secret or proprietary materials as defined by the laws of the State of New York must be clearly marked and identified as such upon submission by the Bidder. Marking the Bid as "confidential" or "proprietary" on its face or in the document header or footer shall not be considered by the Director to be sufficient without specific justification as to why disclosure of particular information in the Bid would cause substantial injury to the competitive position of the Bidder. Bidders/Contractors intending to seek an exemption from disclosure of these materials under the Freedom of Information Law must request the exemption in writing, setting forth the reasons for the claimed exemption. Acceptance of the claimed materials does not constitute a determination on the exemption request, which determination will be made in accordance with statutory procedures. Properly identified information that has been designated confidential, trade secret, or proprietary by the Bidder will not be disclosed except as may be required by the Freedom of Information Law or other applicable State and federal laws.

13. **RELEASE OF BID EVALUATION MATERIALS** Requests concerning the evaluation of Bids may be submitted under the Freedom of Information Law.

14. **FREEDOM OF INFORMATION LAW** During the evaluation process, the content of each Bid will be held in confidence and details of any Bid will not be revealed (except as may be required under the Freedom of Information Law or other State law). The Freedom of Information Law provides for an exemption from disclosure for trade secrets or information the disclosure of which would cause injury to the competitive position of commercial enterprises. This exception would be effective both during and after the evaluation process. If the Bid contains any such trade secret or other confidential or proprietary information, it must be accompanied in the Bid with a written request to the Director to not disclose such information. Such request must state with particularity the reasons why the information should not be available for disclosure and must be provided at the time of submission of the Bid. Notations in the header, footer or watermark of the Bid Document will not be considered sufficient to constitute a request for non-disclosure of trade secret or other confidential or proprietary information. Where a Freedom of Information request is made for trademark or other confidential or proprietary information, the Director reserves the right to determine upon written notice to the Bidder whether such information qualifies for the exemption for disclosure under the law. Notwithstanding the above, where a Bid tabulation is prepared and Bids publicly opened, such Bid tabulation shall be available upon request.

15. **PREVAILING WAGE RATES - PUBLIC WORKS AND BUILDING SERVICES CONTRACTS** If any portion of work being Bid is subject to the prevailing wage rate provisions of the Labor Law, the following shall apply:

A. **"Public Works" and "Building Services" - Definitions**

i. **Public Works** Labor Law Article 8 applies to contracts for public improvement in which laborers, workers or mechanics are employed on a "public works" project (distinguished from public "procurement" or "service" contracts). The Authority, a public benefit corporation, a municipal corporation (including a school district), or a commission appointed by law must be a party to the Contract. The wage and hours provision applies to any work performed by Contractor or Subcontractors.

ii. **Building Services** Labor Law Article 9 applies to Contracts for building service work over \$1,500 with a public agency, that: (i) involve the

care or maintenance of an existing building, or (ii) involve the transportation of office furniture or equipment to or from such building, or (iii) involve the transportation and delivery of fossil fuel to such building, and (iv) the principal purpose of which is to furnish services through use of building service employees.

B. **Prevailing Wage Rate Applicable to Bid Submissions** A copy of the applicable prevailing wage rates to be paid or provided are annexed to the Bid Documents. Bidders must submit Bids which are based upon the prevailing hourly wages, and supplements in cash or equivalent benefits (i.e., fringe benefits and any cash or non-cash compensation which are not wages, as defined by law) that equal or exceed the applicable prevailing wage rate(s) for the location where the work is to be performed. Bidders may not submit Bids based upon hourly wage rates and supplements below the applicable prevailing wage rates as established by the New York State Department of Labor. Bids that fail to comply with this requirement will be disqualified.

C. **Wage Rate Payments / Changes During Contract Term** The wages to be paid under any resulting Contract shall not be less than the prevailing rate of wages and supplements as set forth by law. It is required that the Contractor keep informed of all changes in the Prevailing Wage Rates during the Contract term that apply to the classes of individuals supplied by the Contractor on any projects resulting from this Contract, subject to the provisions of the Labor Law. Contractor is solely liable for and must pay such required prevailing wage adjustments during the Contract term as required by law.

D. **Public Posting and Certified Payroll Records** In compliance with Article 8, Section 220 of the New York State Labor Law:

i. **Posting** The Contractor must publicly post on the work site, in a prominent and accessible place, a legible schedule of the prevailing wage rates and supplements.

ii. **Payroll Records** Contractors and Subcontractors must keep original payrolls or transcripts subscribed and affirmed as true under the penalties of perjury as required by law. For public works contracts over \$25,000 where the Contractor maintains no regular place of business in New York State, such records must be kept at the work site. For building services contracts, such records must be kept at the work site while work is being performed.

iii. **Submission of Certified Payroll Transcripts for Public Works Contracts Only** Contractors and Subcontractors on public works projects must submit monthly payroll transcripts to the Authority that has prepared or directs the preparation of the plans and specifications for a public works project, as set forth in the Bid Specifications. Upon mutual agreement of the Contractor and the Authorized User, the form of submission may be submitted in a specified disk format acceptable to the Department of Labor provided: (1) the Contractor/Subcontractor retains the original records; and, (2) an original signed letter by a duly authorized individual of the Contractor or Subcontractor attesting to the truth and accuracy of the records accompanies the disk. This provision does not apply to Article 9 of the Labor Law building services contracts.

iv. **Records Retention** Contractors and Subcontractors must preserve such certified transcripts for a period of three years from the date of completion of work on the awarded contract.

E. **Day's Labor** Eight hours shall constitute a legal day's work for all classes of employees in this state except those engaged in farm and domestic service unless otherwise provided by law.

No laborers, workmen or mechanics in the employ of the Contractor, Subcontractor or other person doing or contracting to do all or part of the work contemplated by the Contract shall be permitted or required to work more than eight hours in any one calendar day or more than five calendar days in any one week except in cases of extraordinary emergency including fire, flood or danger to life or property. "Extraordinary emergency" shall be deemed to include situations in which sufficient laborers, workers and mechanics cannot be employed to carry on public work expeditiously as a result of such restrictions upon the number of hours and days of labor and the immediate commencement or prosecution or completion without undue delay of the public work is necessary in the judgment of the New York State Commissioner of Labor for the preservation of the Contract site or for the protection of the life and limb of the persons using the Contract site.

16. APPRENTICESHIP TRAINING PROGRAMS PUBLIC WORKS AND BUILDING SERVICES CONTRACTS

Any Bidder/Contractor entering into a Contract with the Authority for public work or building services, or any sub-contractor entering into a sub-contract with a Contractor who has a Contract with the Authority for public work or building services, shall submit verification that they have in-place or will participate in an apprenticeship training program appropriate for the type and nature of work to be performed which have been registered with and approved by the New York State Commission of Labor, pursuant to §816-b of the New York State Labor Law, any provision contained in §103 of the General Municipal Law to the Bidder/Contractor notwithstanding.

A sub-contractor entitled to receive less than \$20,000 from a Bidder/Contractor sub-contract is exempt from the requirement set forth herein.

17. TAXES

A. Unless otherwise specified in the Bid Specifications or Contract, the quoted Bid price includes all taxes applicable to the transaction.

B. Purchases made by the Authority are exempt from New York State sales and excise taxes. These taxes are not to be included in Bids. This exemption does not, however, apply to tools, machinery, equipment or other property, sold or leased to the Contractor or a subcontractor, or to materials and supplies of a kind which will not be incorporated into the completed Product, and the Contractor and his subcontractors shall be responsible for and pay any and all applicable taxes including Sales and Compensating Use Taxes, on such leased tools, machinery, equipment or other property or on such unincorporated materials and supplies, and the provisions set forth below will not be applicable to such tools, machinery, equipment, property and unincorporated materials and supplies.

C. New York State Truck Mileage and Unemployment Insurance or Federal Social Security taxes remain the sole responsibility of the Bidder/Contractor, as no person, firm or corporation is exempt from paying them.

D. Pursuant to Revised Tax Law 5-a, Contractor will be required to furnish sales tax certification on its behalf and for its affiliates, and subcontractors for Contracts with a value greater than \$100,000 in accordance with provisions of the law.

18. PRODUCT REFERENCES

A. **Trade Customs** There shall be no inferences to trade customs, terms, discounts or conditions on sale applicable, which are not specifically expressed in the specifications and proposals on which the award is based nor contrary to the State Finance Law.

B. **"Or Equal"** In all Bid Specifications the words "or equal" are understood to apply where a copyrighted, brand name, trade name, catalog reference, or patented Product is referenced. References to such specific Product are intended as descriptive, not restrictive, unless otherwise stated.

Comparable Product will be considered if proof of compatibility is provided, including appropriate catalog excerpts, descriptive literature, specifications and test data, etc. The Director's decision as to acceptance of the Product as equal shall be final.

C. **Discrepancies in References** In the event of a discrepancy between the model number referenced in the Bid Specifications and the written description of the Products which cannot be reconciled, with respect to such discrepancy, then the written description shall prevail.

19. **REMANUFACTURED, RECYCLED, RECYCLABLE OR RECOVERED MATERIALS** Upon the conditions specified in the Bid Specifications and in accordance with the laws of the State of New York, Contractors are encouraged to use recycled, recyclable or recovered materials in the manufacture of Products and packaging to the maximum extent practicable without jeopardizing the performance or intended end use of the Product or packaging unless such use is precluded due to health, welfare, safety requirements or in the Bid Specifications. Contractors are further encouraged to offer remanufactured Products to the maximum extent practicable without jeopardizing the performance or intended end use of the Product and unless such use is precluded due to health, welfare, safety requirements or by the Bid Specifications. Where such use is not practical, suitable, or permitted by the Bid Specifications, Contractor shall deliver new materials in accordance with the "Warranties" set forth below.

Items with recycled, recyclable, recovered, refurbished or remanufactured content must be identified in the Bid or Bidder will be deemed to be offering new Product.

20. **PRODUCTS MANUFACTURED IN PUBLIC INSTITUTIONS** Bids offering Products that are manufactured or produced in public institutions will be rejected.

21. **PRICING**

A. **Unit Pricing** If required by the Bid Specifications, the Bidder should insert the price per unit specified and the price extensions in decimals, not to exceed four places for each item unless otherwise specified, in the Bid. In the event of a discrepancy between the unit price and the extension, the unit price shall govern unless, in the sole judgment of the Director, such unit pricing is obviously erroneous.

B. **Net Pricing** Unless otherwise required by the Bid Specifications, prices shall be net, including transportation, customs, tariff, delivery and other charges fully prepaid by the Contractor to the destination(s) indicated in the Bid Specifications, subject to the cash discount.

C. **"No Charge" Bid** When Bids are requested on a number of Products as a Group or Lot, a Bidder desiring to Bid "no charge" on a Product in the Group or Lot must clearly indicate such. Otherwise, such Bid may be considered incomplete and be rejected, in whole or in part, at the discretion of the Director.

D. **Educational Pricing** All Products to be supplied for educational purposes that are subject to educational discounts shall be identified in the Bid and such discounts shall be made available to qualifying institutions.

E. **Third Party Financing** If Product acquisitions are financed through any third party financing, Contractor may be required as a condition of Contract Award to agree to the terms and conditions of a "Consent & Acknowledgment Agreement" in a form acceptable to the Director.

F. **Best Pricing Offer** During the Contract term, if substantially the same or a smaller quantity of a Product is sold by the Contractor outside of this Contract upon the same or similar terms and conditions as that of this Contract at a lower price to a federal, state or local governmental entity, the price under this Contract, at the discretion of the Director, shall be immediately reduced to the lower price. Price decreases shall take effect automatically during the Contract term and apply to Purchase Orders submitted on or after:

(i) GSA Changes: Where Authority Net Prices are based on an approved GSA Schedule, the date the approved GSA Schedule pricing decreases during the Contract term; or

(ii) Commercial Price List Reductions: Where Authority Net Prices are based on a discount from Contractor's list prices, the date Contractor lowers its pricing to its customers generally or to similarly situated government customers during the Contract term; or

(iii) Special Offers/Promotions Generally: Where Contractor generally offers more advantageous special price promotions or special discount pricing to other customers during the Contract term for a similar quantity, and the maximum price or discount associated with such offer or promotion is better than the discount or Net Price otherwise available under this Contract, such better price or discount shall apply for similar quantity transactions under this Contract for the life of such general offer or promotion.

G. **Best and Final Prices** As specified in the Bid Documents and Contract, a Contractor may be solicited at the time of issuance of a Purchase Order award for best and final pricing for the Product or service to be delivered to the Authority. Contractors are encouraged to reduce their pricing upon receipt of such request.

22. **DRAWINGS**

A. **Drawings Submitted With Bid** When the Bid Specifications require the Bidder to furnish drawings and/or plans, such drawings and/or plans shall conform to the mandates of the Bid Documents and shall, when approved by the Director, be considered a part of the Bid and of any resulting Contract. All symbols and other representations appearing on the drawings shall be considered a part of the drawing.

i. **Standard Practices** In performing the services required under the Bid Specifications/Contract, the Bidder/Contractor shall follow and adhere to the following standard Authority practices. The following practices may be supplemented or modified, in writing, by the Director.

a. All work shall be in charge of an Engineer, Surveyor or Architect (as appropriate) duly licensed and registered in the State of New York, and experienced in the type of work to be performed for the Authority.

b. Any and all reports shall be of 8½" x 11" format with the 11" dimension being the vertical size. Cover and binding shall be as specified by the Authority. Oversize exhibits (if required) shall be foldouts or shall be contained within a "Pocket" bound into the report.

c. Any specifications shall: (i) Be of 8½" x 11" format; (ii) Be printed, and color coded, in accordance with standard Authority practice;

(d) Have a cover with content and format which shall conform to current Authority practices.

d. The word "plans" shall be synonymous with the words "drawings". Any plans shall: (i) Have a title sheet conforming to current Authority practice; (ii) Be signed and sealed by an Engineer, Surveyor or Architect (as appropriate) duly licensed and registered in the State of New York on the title sheet; (iii) Be ink on mylar, or be an accurate photographic mylar reproduction of any work originally done in pencil; (iv) Be of the following size:

(a) 8½" x 11", or fold-out multiples thereof, if to be bound into the specifications book, subject to approval by the Director.

(b) A minimum of 22" x 36" to a maximum of 36" x 48" to be approved by the Director.

(c) CADD generated drawings shall be plotted on mylar reproducible and the CADD files shall be additionally provided to the Authority on disc in a format acceptable to the Authority.

e. Notwithstanding any of these provisions, the Bidder/Contractor shall, in all cases, conform to any special requirements of other government agencies where such conformity is a required condition for funding, grant approval, or submission/approval of applications and the like.

B. Ownership of Documents All completed original tracings and the original master specification sheets shall constitute the property of the Authority but may, during the course of the performance of the work required by the Bid Specification/Contract, remain in custody of the Contractor unless otherwise directed by the Director. In the event of any revisions in specifications or original drawings, the Contractor shall submit two revised copies to the Director.

C. Surrender of Documents Upon termination or completion of the Contract, the Contractor shall surrender, within fifteen (15) days to the Director (as applicable), all data, reports, maps, surveys, material specifications, contacts, budgets, salary schedules, time records, plans, tracings, sketches, charts, photographs and exhibits prepared, developed or kept in connection with or as a part of this project. This section does not apply to any records or documents pertaining to the operation of the Contractor's business. The Contractor may retain in its possession copies of those records or documents, which it considers necessary for proof of performance.

D. Drawings Submitted During the Contract Term Where the Contract require the Contractor to develop, maintain and deliver diagrams or other technical schematics regarding the scope of work, Contractor shall do so on an ongoing basis at no additional charge, and must, as a condition of payment, update drawings and plans during the Contract term to reflect additions, alterations, and deletions. Such drawings and diagrams shall be delivered to the Authority's representative and shall be in accordance with the requirements set forth in Section 22(A).

E. Accuracy of Drawings Submitted All drawings shall be neat and of professional quality and technical accuracy. The drawings shall coordinate all designs, drawings, specifications and other services furnished by the Bidder/Contractor under the Bid Specifications/Contract. The Contractor shall, without additional compensation, correct or revise any errors or deficiencies in its designs, drawings, specifications, and other services, unless otherwise agreed upon by the Director. Neither the Authority's review, approval or acceptance of, nor payment for, the drawings under this contract shall be construed to operate as a waiver of any rights under the Contract or of any cause of action arising out of the performance of the Contract, and the Contractor shall be and remain liable to the Authority in accordance with applicable law for all damages to the Authority caused by the Contractor's negligent performance or breach of contract of any of the services furnished under the Contract. The rights and remedies of the Authority provided for in the Contract are in addition to any other rights and remedies provided by law.

F. Claims In the event that any claim is made or any action brought in any way relating to the plans and specifications drawn by the Contractor, the Contractor will diligently render to the Authority any and all assistance, which the Authority may require of the Contractor at the Contractor's sole cost and expense. None of the above shall be deemed in any way a waiver of the Contractor's responsibility for the information provided by his (its) drawings, specifications and work.

23. LABORATORY WORK If any portion of work being Bid is subject to laboratory testing, the following shall apply:

A. Any and all testing work required under this Contract shall be subject to the approval of the Director prior to undertaking any such testing program.

B. The Director will determine if it is in the best interests of the Authority to use the facilities of private testing laboratories or those of public agencies such as the Nassau County Department of Public Works, or a combination of both.

C. The Contractor shall review the testing results and shall state, in writing, that they are acceptable or unacceptable.

D. If private testing laboratories are used, the Contractor shall process the claims for payment and shall submit its certification that the amount of the claim is reasonable and proper.

24. SITE INSPECTION Where a site inspection is required by the Bid Specifications or Project Definition, Bidder shall be required to inspect the site, including environmental or other conditions for pre-existing deficiencies that may affect the installed Product, equipment, or environment or services to be provided and, which may affect Bidder's ability to properly deliver, install or otherwise provide the required Product. All inquiries regarding such conditions shall be made in writing. Bidder shall be deemed to have knowledge of any deficiencies or conditions which such inspection or inquiry might have disclosed. Bidder must provide a detailed explanation with its Bid if additional work is required under this clause in order to properly complete the delivery and installation of the required Product or provide the requested service.

25. SAMPLES

A. **Standard Samples** Bid Specifications may indicate that the Product to be purchased must be equal to a standard sample on display in a place designated by the Director and such sample will be made available to the Bidder for examination prior to the opening date. Failure by the Bidder to examine such sample shall not entitle the Bidder to any relief from the conditions imposed by the Bid Specifications.

B. **Bidder Supplied Samples** The Director reserves the right to request from the Bidder/Contractor a representative sample(s) of the Product offered at any time prior to or after award of a contract. Unless otherwise instructed, samples shall be furnished within the time specified in the request. Untimely submission of a sample may constitute grounds for rejection of Bid or cancellation of the Contract. Samples must be submitted free of charge and be accompanied by the Bidder's name and address, any descriptive literature relating to the Product and a statement indicating how and where the sample is to be returned. Where applicable, samples must be properly labeled with the appropriate Bid or Contract reference.

A sample may be held by the Director during the entire term of the Contract and for a reasonable period thereafter for comparison with deliveries. At the conclusion of the holding period the sample, where feasible, will be returned as instructed by the Bidder, at the Bidder's expense and risk. Where the Bidder has failed to fully instruct the Director as to the return of the sample (*i.e.*, mode and place of return, etc.) or refuses to bear the cost of its return, the sample shall become the sole property of the receiving entity at the conclusion of the holding period.

C. **Enhanced Samples** When an approved sample exceeds the minimum specifications, all Product delivered must be of the same enhanced quality and identity as the sample. Thereafter, in the event of a Contractor's default, the Director may procure a Product substantially equal to the enhanced sample from other sources, charging the Contractor for any additional costs incurred.

D. **Conformance with Sample(s)** Submission of a sample (whether or not such sample is tested by, or for, the Director) and approval thereof shall not relieve the Contractor from full compliance with all terms and conditions, performance related and otherwise, specified in the Bid Specifications.

If in the judgment of the Director the sample or product submitted is not in accordance with the specifications or testing requirements prescribed in the Bid Specifications, the Director may reject the Bid. If an award has been made, the Director may cancel the Contract at the expense of the Contractor.

E. **Testing** All samples are subject to tests in the manner and place designated by the Director, either prior to or after Contract award. Unless otherwise stated in the Bid Specifications, Bidder samples consumed or rendered useless by testing will not be returned to the Bidder. Testing costs for samples that fails to meet Contract requirements may be at the expense of the Contractor.

SAMPLES MUST BE SUBMITTED IN STRICT ACCORDENCE WITH THIS SECTION. THE AUTHORITY RETAINS THE ABSOLUTE RIGHT TO REJECT ANY BID FOR FAILURE TO COMPLY WITH THIS SECTION.

BID EVALUATION

26. BID EVALUATION The Director reserves the right to accept or reject any and all Bids, or separable portions of offers, and waive technicalities, irregularities, and omissions if the Director determines the best interests of the Authority will be served. The Director, in his/her sole discretion, may accept or reject illegible, incomplete or vague Bids and his/her decision shall be final. A conditional or revocable Bid which clearly communicates the terms or limitations of acceptance may be considered, and Contract award may be made in compliance with the Bidder's conditional or revocable terms in the offer.

27. CONDITIONAL BID Unless the Bid Specifications provides otherwise, a Bid is not rendered non-responsive if the Bidder specifies that the award will be accepted only on all or a specified group of items or Product included in the specification. It is understood that nothing herein shall be deemed to change or alter the method of award contained in the Bid Documents.

28. CLARIFICATIONS / REVISIONS Prior to award, the Director reserves the right to seek clarifications, request Bid revisions, or to request any information deemed necessary for proper evaluation of Bids from all Bidders deemed to be eligible for Contract award. Failure to provide requested information may result in rejection of the Bid.

29. EQUIVALENT OR IDENTICAL BIDS In the event that two or more Bidders submit substantially equivalent Bids as to pricing or other factors, the decision of the Director to award a Contract to one or more of such Bidders shall be final.

30. PROMPT PAYMENT DISCOUNTS While prompt payment discounts will not be considered in determining the low Bid, the Director may consider any prompt payment discount in resolving Bids which are otherwise tied. However, any notation indicating that the price is net, (*e.g., net 30 days*), shall be understood to mean only that no prompt payment discount is offered by the Bidder. The imposition of service, interest, or other charges, except as otherwise permitted by law, may render the Bid non-responsive and may be cause for its rejection.

31. PERFORMANCE AND RESPONSIBILITY QUALIFICATIONS The Director reserves the right to investigate or inspect at any time whether or not the Product, services, qualifications or facilities offered by the Bidder/Contractor meet the requirements set forth in the Bid Specifications/Contract or as set forth during Contract negotiations. Contractor shall at all times during the Contract term remain responsible and responsive. If the Director determines that the conditions and terms of the Bid Documents, Bid Specifications or Contract are not complied with, or that items, services or Product proposed to be furnished do not meet the specified requirements, or that the legal authority, integrity experience, ability, prior performance, organization and financial capacity or facilities are not satisfactory, the Director may reject such Bid or terminate the Contract.

32. QUANTITY CHANGES PRIOR TO AWARD The Director reserves the right, at any time prior to the award of a specific quantity Contract, to alter in good faith the quantities listed in the Bid Specifications. In the event such right is exercised, the lowest responsible Bidder meeting Bid Specifications will be advised of the revised quantities and afforded an opportunity to extend or reduce its Bid price in relation to the changed quantities. Refusal by the low Bidder to so extend or reduce its Bid price may result in the rejection of its Bid and the award of such Contract to the lowest responsible Bidder who accepts the revised qualifications.

33. TIMEFRAME FOR OFFERS The Director reserves the right to make awards within forty-five (45) days after opening of Bids, during which period, Bids must remain firm and cannot be withdrawn. Any Bid which expressly states therein that acceptance must be made within a shorter specified time, may at the sole discretion of the Director, be accepted or rejected.

TERMS & CONDITIONS

34. CONTRACT CREATION / EXECUTION Subject to Award and upon receipt of all required approvals as set forth in the Bid Specifications, a Contract shall be deemed executed and created with the successful Bidder(s), upon receipt of: (A) a fully executed Contract; or (B) a Purchase Order authorized by the Director.

35. MODIFICATION OF CONTRACT TERMS The terms and conditions set forth in the Contract shall govern all transactions by and between the Authority and the Contractor under this Contract. The Contract may only be modified or amended upon mutual written agreement of the Director and Contractor.

The Contractor may, however, offer more advantageous pricing, payment, or other terms and conditions than those set forth in the Contract. In such event, a copy of such terms shall be furnished to the Director by the Contractor at the time of such offer.

Other than where such terms are more advantageous for the Authority than those set forth in the Contract, no alteration or modification of the terms of the Contract, including substitution of Product, shall be valid or binding against the Authority unless authorized by the Director. No such

alteration or modification shall be made by unilaterally affixing such terms to Product upon delivery (including, but not limited to, attachment or inclusion of standard pre-printed order forms, product literature, "shrink wrap" terms accompanying software upon delivery, or other documents) or by incorporating such terms onto order forms, purchase orders or other documents forwarded by the Contractor for payment, notwithstanding the Authority's subsequent acceptance of Product, or that the Authority has subsequently processed such document for approval or payment.

36. SCOPE CHANGES The Director reserves the right, unilaterally, to require, by written order, changes by altering, adding to or deducting from the Bid Specifications, such changes to be within the general scope of the Contract. The Director may make an equitable adjustment in the Contract price or delivery date if the change affects the cost or time of performance. Such equitable adjustments require the consent of the Contractor, which consent shall not be unreasonably withheld.

37. ESTIMATED / SPECIFIC QUANTITY CONTRACTS Estimated quantity contracts are expressly agreed and understood to be made for only the quantities, if any, actually ordered during the Contract term. No guarantee of any quantity(s) is implied or given. The Authority will neither be compelled to order any quantities of any item nor will it be limited to the quantity indicated for any item. The quantity to be ordered will be such as may actually be required, as determined by the Authority. *The Authority retains the absolute right to reject any Bid which expressly imposes a minimum order quantity or minimum dollar amount.* Purchases by the Authority from Contracts for services and technology are voluntary.

38. EMERGENCY CONTRACTS In the event that a disaster emergency is declared by the Authority, or it determines that an emergency exists requiring the prompt and immediate delivery of Product, the Authority reserves the right to obtain such Product from any source, including but not limited to this Contract(s), as the Authority in its sole discretion determines will meet the needs of such emergency. Contractor shall not be entitled to any claim or lost profits for Product procured from other sources pursuant to this paragraph.

39. PURCHASE ORDERS Unless otherwise authorized in writing by the Director, no Product is to be delivered or furnished by Contractor until transmittal of an official Purchase Order from the Authority. Unless terminated or cancelled pursuant to the authority vested in the Authority, Purchase Orders shall be effective and binding upon the Contractor when placed in the mail or electronically transmitted prior to the termination of the contract period, addressed to the Contractor at the address for receipt of orders set forth in the Contract or in the Award.

All Purchase Orders issued pursuant to Contracts let by the Director must bear the appropriate Contract number. As deemed necessary, the Authority may confirm pricing and other Product information with the Contractor prior to placement of the Purchase Order. The Authority reserves the right to require any other information from the Contractor which the Authority deems necessary in order to complete any Purchase Order placed under the Contract. Should the Authority add written terms and conditions to the Purchase Order that conflict with the terms and conditions of the Contract, the Contractor has the option of rejecting the Purchase Order within *five business days* of its receipt but shall first attempt to negotiate the additional written terms and conditions in good faith with the Authority, or fulfill the Purchase Order. Notwithstanding the above, the Authority reserves the right to dispute any discrepancies arising from the presentation of additional terms and conditions with the Contractor.

40. PRODUCT DELIVERY Delivery must be made as ordered to the address specified in a schedule of locations as indicated on the Purchase Order and in accordance with the terms of the Contract. Unless otherwise specified in the Bid Documents/Bid Specifications, delivery shall be made within *thirty calendar days* after receipt of a Purchase Order by the Contractor.

The decision of the Director as to compliance with delivery terms shall be final. The burden of proof for delay in receipt of Purchase Order shall rest with the Contractor. In all instances of a potential or actual delay in delivery, the Contractor shall immediately notify the Director, and confirm in writing the explanation of the delay, and take appropriate action to avoid any subsequent late deliveries. Any extension of time for delivery must be requested in writing by the Contractor and approved in writing by the Authority. Failure to meet such delivery time schedule may be grounds for cancellation of the order or, in the Director's discretion, the Contract.

The Authority further reserves the absolute right to authorize the immediate purchase of the Product from other sources. Purchase from other sources (without recourse to and by the Contractor for the costs and expenses thereof) to replace all or part of the Products which are the subject of the delay, may be deducted from the Contract quantities without penalty or liability to the Authority. The Contractor shall promptly reimburse the Authority for any excess cost incurred in replacing all or part of the Products which are the subject of the delay. The Contractor shall have no claim against the Authority for the difference in cost where the cost of the purchase is less than that provided in the Contract.

41. WEEKEND AND HOLIDAY DELIVERIES Unless otherwise specified in the Bid Specifications or by the Authority, deliveries will be scheduled for ordinary business hours, Monday through Friday (excluding legal holidays observed by the Authority). Deliveries may be scheduled by mutual agreement for Saturdays, Sundays or legal holidays observed by the Authority where the Product is for daily consumption, an emergency exists, the delivery is a replacement, delivery is late, or other reasonable circumstance in which event the convenience of the Authority shall govern.

42. SHIPPING/RECEIPT OF PRODUCT

A. Packaging Tangible Product shall be securely and properly packed for shipment, storage and stocking in appropriate, clearly labeled shipping containers and according to accepted commercial practice, without any extra charges for packing materials, cases or other types of containers. The container shall become and remain the property of the Authority unless otherwise specified in the Contract documents.

B. Shipping Charges Unless otherwise stated in the Bid Specifications, all deliveries shall be deemed to be freight on board (F.O.B.) destination tailgate delivery at the Authority or its designated location listed in the Contract or Purchase Order. Unless otherwise agreed, items purchased at a price

F.O.B. Shipping point plus transportation charges shall not relieve the Contractor from responsibility for safe and proper delivery notwithstanding the Authority's payment of transportation charges. Contractor shall be responsible for ensuring that the Bill of Lading states "charges prepaid" for all shipments.

C. Receipt of Product The Contractor shall be solely responsible for assuring that deliveries are made to personnel authorized to accept delivery on

behalf of the Authority. Any losses resulting from the Contractor's failure to deliver Product to authorized personnel shall be borne exclusively by the Contractor.

43. TITLE AND RISK OF LOSS Notwithstanding the form of shipment, title or other property interest, risk of loss shall not pass from the Contractor to the Authority until the Products have been received, inspected and accepted by the receiving entity. Acceptance shall occur within a reasonable time or in accordance with such other defined acceptance period as may be specified in the Bid Specifications or Purchase Order. Mere acknowledgment by Authority personnel of the delivery or receipt of goods (*e.g., signed bill of lading*) shall not be deemed or construed as acceptance of the Products received. Any delivery of Product that is substandard or does not comply with the Bid Specifications or Contract terms and conditions, may be rejected or accepted on an adjusted price basis, as determined by the Director.

44. RE-WEIGHING PRODUCT Deliveries are subject to re-weighing at the point of destination by the Authority. If shrinkage occurs which exceeds that normally allowable in the trade, the Authority shall have the option to require delivery of the difference in quantity or to reduce the payment accordingly. Such option shall be exercised in writing by the Authority.

45. PRODUCT SUBSTITUTION In the event a specified manufacturer's Product listed in the Contract becomes unavailable or cannot be supplied by the Contractor for any reason (except as provided for in the Savings/Force Majeure Clause) a Product deemed in writing by the Director to be equal to or better than the specified Product must be substituted by the Contractor at no additional cost or expense to the Authority. Unless otherwise specified, any substitution of Product prior to the Director's written approval may be cause for cancellation of Contract.

46. REJECTED PRODUCT When Product is rejected, it must be removed by the Contractor from the premises of the Authority within ten calendar days of notification of rejection by the Authority. Upon notification of rejection, risk of loss of rejected or non-conforming Product shall remain with Contractor. Rejected items not removed by the Contractor within ten calendar days of notification shall be regarded as abandoned by the Contractor, and the Authority shall have the right to dispose of Product as its own property. The Contractor shall promptly reimburse the Authority for any and all costs and expenses incurred in storage or effecting removal or disposition after the ten-calendar day period.

47. INSTALLATION Where installation is required, Contractor shall be responsible for placing and installing the Product in the required locations. All materials used in the installation shall be of good quality and shall be free from any and all defects that would mar the appearance of the Product or render it structurally unsound. Installation includes the furnishing of any equipment, rigging and materials required to install or place the Product in the proper location. The Contractor shall protect the Site from damage for all its work and shall repair damages or injury of any kind caused by the Contractor, its employees, officers or agents.

If any alteration, dismantling or excavation, etc. is required to effect installation:

- A. The Contractor shall promptly restore the structure or site following alteration, dismantling or excavation, etc. Upon completion of the work, the building and surrounding area of work shall be left clean and in a neat, unobstructed condition, and everything in satisfactory repair and order.
- B. Work shall be performed to cause the least inconvenience to the Authority and with proper consideration for the rights of other Contractors or workers. The Contractor shall promptly perform its work and shall coordinate its activities with those of other Contractors.
- C. The Contractor shall be responsible for daily clean up of all wastes of every kind arising from all activity at the work site, including but not limited to dust, refuse, rubbish garbage, scrap metal, construction debris and packaging material, etc., so that the work site shall present a safe, neat, orderly and workmanlike appearance at all times.
- D. The Contractor shall clean up and remove all debris and rubbish from its work as required or directed in accordance with all Federal, State and Local Laws and Regulations governing the disposal of materials, debris, rubbish and trash on or off the site. Each Contractor shall provide applicable certifications and affidavits of proper disposals as requested by the Authority. Burying or burning of any material will not be permitted.
- E. The Contractor shall further be responsible for the removal and legal disposal of any other type of waste material resulting from this contract as well as for any and all costs associated with such proper and legal disposal of these materials. No separate payment will be made for this disposal. Any costs thereof shall be included within the unit price costs for the Contract Items.

48. REPAIRED OR REPLACED PARTS / COMPONENTS Where the Contractor is required to repair, replace or substitute Product or parts or components of the Product under the Contract, the repaired, replaced or substituted Products shall be subject to all terms and conditions for new parts and components set forth in the Contract including Warranties, as set forth in the Additional Warranties Clause herein. Replaced or repaired Product or parts and components of such Product shall be new and shall, if available, be replaced by the original manufacturer's component or part. Remanufactured parts or components meeting new Product standards may be permitted by the Authority. Before installation, all proposed substitutes for the original manufacturer's installed parts or components must be approved by the Director. The part or component shall be equal to or of better quality than the original part or component being replaced.

49. ON-SITE STORAGE With the written approval of the Director, materials, equipment or supplies may be stored at the Site at the Contractor's sole risk.

50. EMPLOYEES, SUBCONTRACTORS & AGENTS All employees, sub-contractors or agents performing work under the Contract must be trained staff or technicians who meet or exceed the professional, technical and training qualifications set forth in the Bid Specifications or the Bid Documents, whichever is more restrictive, and must comply with all security and administrative requirements of the Authority. The Director reserves the right to conduct a security background check or otherwise approve any employee, sub-contractor or agent furnished by Contractor and to refuse access to or require replacement of any personnel for cause based on, including but not limited to, professional, technical or training qualifications, quality of work or change in security status or non-compliance with Authority's security or other requirements. Such approval shall not relieve the Contractor of the obligation to perform all work in compliance with the Contract terms. The Director reserves the right to reject and/or bar from the facility for cause any employee, sub-contractor, or agents of the Contractor.

51. ASSIGNMENT The Contractor shall not assign, transfer, convey, sublet, or otherwise dispose of the contract or its right, title or interest therein, or its power to execute such contract to any other person, company, firm or corporation in performance of the contract without the prior

written consent of the Authority. Failure to obtain consent to assignment from the Authority shall revoke and annul such Contract. Prior to a consent to assignment of a Contract, or portion thereof, becoming effective, the Contractor shall submit the request to assignment to the Director and seek written agreement from the Director. The Director reserves the right to reject any proposed assignee in his/her discretion.

52. SUBCONTRACTORS AND SUPPLIERS The Contractor shall advise the Director, in writing, as to the name and address of the proposed sub-contractor and the exact scope of the work the sub-contractor will perform. The Contractor shall not sub-contract with the sub-contractor until the Director has given written approval of the sub-contractor and the work to be performed. All work by sub-contractors shall be performed at no additional cost to the Authority except as herein elsewhere stated in the Contract. All sub-contractors shall be required to furnish the Authority with proof of insurance in the same manner and the amounts as required by the Contractor. All sub-contractors shall be required to comply with the applicable terms and conditions of the Contract.

The Director reserves the right to reject any proposed Subcontractor or supplier for bona fide business reasons, which may include, but are not limited to: they are on the New York State Department of Labor's list of companies with which New York State cannot do business; the Director determines that the company is not qualified; the Director determines that the company is not responsible; the company has previously provided unsatisfactory work or services; the company failed to solicit minority and women's business enterprises (M/WBE) Bidders as required by prior Contracts.

53. PERFORMANCE / BID BOND The Director reserves the right to require a Bidder or Contractor to furnish without additional cost, a performance, payment or Bid bond or negotiable irrevocable letter of credit or other form of security for the faithful performance of the Contract. Where required, such bond or other security shall be in the form prescribed by the Authority Attorney of the Authority of North Hempstead. Failure of the Contractor to furnish said surety within ten days from the date of request shall be sufficient cause to terminate the Contract and cancel a pending Purchase Order(s).

54. SUSPENSION OF WORK The Director, in his/her sole discretion, reserves the right to suspend any or all activities under this Contract, at any time, in the best interests of the Authority. In the event of such suspension, the Contractor will be given a formal written notice outlining the particulars of such suspension. Examples of the reason for such suspension include, but are not limited to, a budget freeze or reduction on Authority spending, declaration of emergency, contract compliance issues or other such circumstances. Upon issuance of such notice, the Contractor is not to accept any Purchase Orders, and shall comply with the suspension order. Activity may resume at such time as the Director issues a formal written notice authorizing a resumption of performance under the Contract.

55. TERMINATION

A. **By written notice:** This Contract may be terminated at any time by the Authority upon sixty (60) days written notice or other specified period without penalty or other early termination charges due. The Authority will be responsible for payment of any portion of the Services completed prior to termination of the Contract and satisfactory to the Authority's Comptroller. Such termination of the Contract shall not affect any project or Purchase Order that has been issued under the Contract prior to the date of such termination. Contractor shall use due diligence and provide any outstanding deliverables.

B. **For Violation of the Sections 139-j and 139-k of the State Finance Law:** The Director reserves the absolute right to terminate the Contract in the event it is found that the certification filed by the Bidder in accordance with Section 139-k of the State Finance Law was intentionally false or intentionally incomplete. Upon such finding, the Director may exercise its termination right by providing written notification to the Contractor in accordance with the written notification terms of the Contract.

C. **For Violation of Revised Tax Law 5a:** The Director reserves the absolute right to terminate the contract in the event it is found that the certification filed by the Contractor in accordance with §5-a of the Tax Law is not timely filed during the term of the Contract or the certification furnished was intentionally false or intentionally incomplete. Upon such finding, the Director may exercise its termination right by providing written notification to the Contractor.

D. **Contractor Assistance Upon Termination.** In connection with the termination or impending termination of the Contract, the Contractor shall, regardless of the reason for termination, take all actions reasonably requested by the Authority to assist the Authority in transitioning the Contractor's responsibilities under the Contract.

E. **Accounting Upon Termination.** Within thirty (30) days of the termination of the Contract, the Contractor shall provide the Authority with a complete accounting up to the date of termination of all monies received from the Authority, and shall immediately refund to the Authority any unexpended balance remaining as of the time of termination.

F. **Reimbursement Upon Termination.** Payment to the Contractor following termination shall not exceed authorized expenditures made prior to termination, and may be suspended by the Authority pending the Contractor's reasonable compliance with the terms and provisions of (D) and (E) above.

56. SAVINGS/FORCE MAJEURE A force majeure occurrence is an event or effect that cannot be reasonably anticipated or controlled. Force majeure includes, but is not limited to, acts of God, acts of war, acts of public enemies, strikes, fires, explosions, actions of the elements, floods, or other similar causes beyond the control of the Contractor or the Director in the performance of the Contract which non-performance, by exercise of reasonable diligence, cannot be prevented. Contractor shall provide the Director with written notice of any force majeure occurrence as soon as the delay is known.

Neither the Contractor nor the Director shall be liable to the other for any delay in or failure of performance under the Contract due to a force majeure occurrence. Any such delay in or failure of performance shall not constitute default or give rise to any liability for damages. The existence of such causes of such delay or failure shall extend the period for performance to such extent as determined by the Contractor and the Director to be necessary to enable complete performance by the Contractor if reasonable diligence is exercised after the cause of delay or failure has been removed.

Notwithstanding the above, at the discretion of the Director where the delay or failure will significantly impair the value of the Contract to the Authority, the Director may:

A. Accept allocated performance or deliveries from the Contractor. The Contractor, however, hereby agrees to grant preferential treatment to the

Authority with respect to Product subjected to allocation; and/or

B. Purchase from other sources (without recourse to and by the Contractor for the costs and expenses thereof) to replace all or part of the Products which are the subject of the delay, which purchases may be deducted from the Contract quantities without penalty or liability to the Authority; or Terminate the Contract or the portion thereof which is subject to delays, and thereby discharge any unexecuted portion of the Contract or the relative part thereof.

In addition, the Director reserves the right, in his/her sole discretion, to make an equitable adjustment in the Contract terms and/or pricing should extreme and unforeseen volatility in the marketplace affect pricing or the availability of supply. "Extreme and unforeseen volatility in the marketplace" is defined as market circumstances which meet the following criteria: (i) the volatility is due to causes outside the control of Contractor; (ii) the volatility affects the marketplace or industry, not just the particular Contract source of supply; (iii) the effect on pricing or availability of supply is substantial; and (iv) the volatility so affects Contractor's performance that continued performance of the Contract would result in a substantial loss.

57. CONTRACT BILLINGS

A. Contractor and the distributors/resellers designated by the Contractor, if any, shall provide complete and accurate billing invoices to the Authority in order to receive payment. None of the Contract amount shall be paid by the Authority except pursuant to timely filed claim forms containing documentation of the costs claimed following completion of all or a portion of the Product or services performed, all in form and substance satisfactory to the Authority.

i. Claim Forms, Claim Form Review and Approval. Payments shall be made to the Contractor in arrears and shall be expressly contingent upon: (a) the Contractor submitting a claim form (the "Claim Form") in a form provided by the Authority, that (i) states with reasonable specificity the Product or services provided and the payment requested as consideration for such Product or services; (ii) certifies that the sum sought is just, true and correct; that no part thereof has been paid except as stated, and that the balance is actually due and owing and that taxes from which the Authority is exempt are excluded; and (iii) is accompanied by documentation satisfactory to the Authority supporting the amount claimed, and review, approval and audit of the Claim Form by the Authority.

ii. Timing of Payment Claims. The Contractor shall submit claims no more frequently than once a month and no later than three (3) months following the Authority's receipt of the Product or services performed that are the subject of the claim. Any claims submitted in violation of this Section 55 shall not be due and payable by the Authority.

iii. No Duplication of Payments. Payments for the Product shall not duplicate payments for any work performed or to be performed under any other agreements made between the Contractor and any funding source including the Authority.

iv. Release The acceptance by the Contractor or any person claiming under the Contractor of any payment made on the final payment claim under this Contract shall operate on and shall be a release to the Authority from all claims and liability to the Contractor, its successors, legal representatives and assigns, for any compensation or reimbursement for services rendered or work performed under or by the provisions of this Contract.

B. The Comptroller shall render payment for Authority purchases, and such payment shall be made in accordance with ordinary Authority procedures and practices.

C. Submission of a Claim Form and payment thereof shall not preclude the Director from reimbursement or demanding a price adjustment in any case where the Product delivered is found to deviate from the terms and conditions of the Contract or where the billing was inaccurate.

D. Contractor shall provide, upon request of the Director or the Comptroller, any and all information necessary to verify the accuracy of the billings. Such information shall be provided in the format requested by the Director or Comptroller and in a media commercially available from the Contractor.

58. REMEDIES FOR BREACH It is understood and agreed that all rights and remedies afforded below shall be in addition to all remedies or actions otherwise authorized or permitted by law:

A. **Cover/Substitute Performance** In the event of Contractor's material breach, the Director may, with or without formally Bidding: (i) Purchase from other sources; or (ii) If the Director is unsuccessful after making reasonable attempts, under the circumstances then existing, to timely obtain acceptable service or acquire replacement Product of equal or comparable quality, the Director may acquire acceptable replacement Product of lesser or greater quality.

Such purchases may, in the discretion of the Director, be deducted from the Contract quantity and payments due Contractor.

B. **Withhold Payment** In any case where a question of non-performance by Contractor arises, payment may be withheld in whole or in part at the discretion of the Director. Should the amount withheld be finally paid, a cash discount originally offered may be taken as if no delay in payment had occurred.

C. **Reimbursement of Costs Incurred** The Contractor agrees to reimburse the Authority promptly for any and all additional costs and expenses incurred for acquiring acceptable services, and/or replacement Product. Should the cost of cover be less than the Contract price, the Contractor shall have no claim to the difference. The Contractor covenants and agrees that in the event suit is successfully prosecuted for any default on the part of the Contractor, all costs and expenses expended or incurred by the Authority in connection therewith, including reasonable attorney's fees, shall be paid by the Contractor.

D. **Substitute Equipment** Where the Contractor fails to timely deliver pursuant to the guaranteed delivery terms of the Contract, the Authority may rent substitute equipment temporarily. Any sums expended for such rental shall, upon demand, be reimbursed to the Authority promptly by the Contractor or deducted by the Authority from payments due or to become due the Contractor on the same or another transaction.

E. **Deduction/Credit** Sums due as a result of these remedies may be deducted or offset by the Authority from payments due, or to become due, the Contractor on the same or another transaction. If no deduction or only a partial deduction is made in such fashion the Contractor shall pay to the Authority the amount of such claim or portion of the claim still outstanding, on demand. The Director reserves the right to determine the disposition of any rebates, settlements, restitution, liquidated damages, etc., which arise from the administration of the Contract.

59. TOXIC SUBSTANCES Each Contractor furnishing a toxic substance as defined by Section 875 of the Labor Law, shall provide the Authority with not less than two copies of a material safety data sheet, which sheet shall include for each such substance the information outlined in Section 876 of the Labor Law.

Before any chemical product is used or applied on or in any building, a copy of the product label and Material Safety Data Sheet must be provided to and approved by the Authority.

60. INDEPENDENT CONTRACTOR The Contractor, in accordance with his status as an independent contractor, covenants and agrees that it will conduct itself consistent with such status, that it will neither hold itself out as, nor claim to be, an officer or employee of the Authority by reason hereof, and that it will not by reason hereof, make any claim, demand or application to or for any right or privilege applicable to an officer or employee of the Authority, including but not limited to, Workmen's Compensation coverage, Unemployment Insurance benefits, Social Security or Retirement membership or credit. The Contractor shall not engage, on a full time or part-time or other basis during the period of the Contract, any professional or technical personnel who are or have been at any time during the period of the Contract in the employ of the Federal Highway Administration or the Public Works organization of any State, County or City or Authority except regularly retired employees, without the consent of the public employer of such person.

61. COOPERATION WITH THIRD PARTIES The Contractor shall be responsible for fully cooperating with any third-party, including but not limited to other Contractors or Subcontractors of the Authority, as necessary to ensure delivery of Product or coordination of performance of services.

62. ADDITIONAL WARRANTIES Where Contractor, product manufacturer or service provider generally offers additional or more advantageous warranties than set forth below, Contractor shall offer or pass through any such warranties to the Authority. Contractor hereby warrants and represents:

- A. **Product Performance** Contractor warrants and represents that Products delivered pursuant to this Contract conform to the manufacturer's specifications, performance standards and documentation, and the documentation fully describes the proper procedure for using the Products.
- B. **Title and Ownership Warranty** Contractor warrants, represents and conveys (i) full ownership, clear title free of all liens, or (ii) the right to transfer or deliver perpetual license rights to any Products transferred to the Authority under this Contract. Contractor shall be solely liable for any costs of acquisition associated therewith. Contractor fully indemnifies the Authority for any loss, damages or actions arising from a breach of said warranty without limitation.
- C. **Contractor Compliance** Contractor represents and warrants to pay, at its sole expense, for all applicable permits, licenses, tariffs, tolls and fees to give all notices and comply with all laws, ordinances, rules and regulations of any governmental entity in conjunction with the performance of obligations under the Contract. Prior to award and during the Contract term and any renewals thereof, Contractor must establish to the satisfaction of the Director that it meets or exceeds all requirements of the Bid/Contract and any applicable laws, including but not limited to, permits, insurance coverage, licensing, proof of coverage for worker's compensation and/or disability benefits, and shall provide such proof as required by the Director. Failure to do so may constitute grounds for the Director to cancel or suspend this Contract, in whole or in part, or to take any other action deemed necessary by the Director.
- D. **Product Warranty** Unless recycled or recovered materials are available in accordance with the "Recycled or Recovered Materials" clause, Product offered shall be standard new equipment, current model or most recent release of regular stock product with all parts regularly used with the type of equipment offered; and no attachment or part has been substituted or applied contrary to the manufacturer's recommendations and standard practice.

Contractor further warrants and represents that components or deliverables specified and furnished by or through Contractor shall individually, and where specified and furnished as a system, be substantially uninterrupted or error-free in operation and guaranteed against faulty material and workmanship for the warranty period, or for a minimum of one (1) year from the date of acceptance, whichever is longer ("Project warranty period"). During the Project warranty period, defects in the materials or workmanship of components or deliverables specified and furnished by or through Contractor shall be repaired or replaced by Contractor at no cost or expense to the Authority. Contractor shall extend the Project warranty period for individual component(s), or for the Product as a whole, as applicable, by the cumulative period(s) of time, after notification, during which an individual component or the Product requires servicing or replacement (down time) or is in the possession of the Contractor, its agents, officers, Subcontractors, distributors, resellers or employees ("extended warranty").

Where Contractor, the Independent Software Vendor "ISV," or other third party manufacturer markets any Project Deliverable delivered by or through Contractor with a standard commercial warranty, such standard warranty shall be in addition to, and not relieve the Contractor from, Contractor's warranty obligations during the project warranty and extended warranty period(s). Where such standard commercial warranty covers all or some of the Project warranty or extended warranty period(s), Contractor shall be responsible for the coordination during the Project warranty or extended warranty period(s) with ISV or other third party manufacturer(s) for warranty repair or replacement of ISV or other third party manufacturer's Product.

Where Contractor, ISV or other third party manufacturer markets any Project Deliverable with a standard commercial warranty which goes beyond the Project warranty or extended warranty period(s), Contractor shall notify the Authority and pass through the manufacturer's standard commercial warranty to the Authority at no additional charge; provided, however, that Contractor shall not be responsible for coordinating services under the third-party extended warranty after expiration of the Project warranty and extended warranty period(s).

E. **Replacement Parts Warranty** If during the regular or extended warranty period's faults develop, the Contractor shall promptly repair or, upon demand, replace the defective unit or component part affected. All costs for labor and material and transportation incurred to repair or replace defective Product during the warranty period shall be borne solely by the Contractor, and the Authority shall in no event be liable or responsible therefor.

Any part of component replaced by the Contractor under the Contract warranty shall be replaced at no cost to the Authority and guaranteed for the greater of: (i) the warranty period under paragraph (D) above; or (ii) if a separate warranty for that part or component is generally offered by the manufacturer, the standard commercial warranty period offered by the manufacturer for the individual part or component.

F. **Virus Warranty** The Contractor represents and warrants that Licensed Software contains no known viruses. Contractor is not responsible for viruses introduced at Licensee's site.

G. **Date/Time Warranty** Contractor warrants that Product(s) furnished pursuant to this Contract shall, when used in accordance with the Product documentation, be able to accurately process date/time data (including, but not limited to, calculating, comparing, and sequencing) transitions, including leap year calculations. Where a Contractor proposes or an acquisition requires that specific Products must perform as a package or system, this warranty shall apply to the Products as a system.

This Date/Time Warranty shall survive beyond termination or expiration of this contract through: (i) ninety (90) days or (ii) the Contractor's or Product manufacturer/developer's stated date/time warranty term, whichever is longer. Nothing in this warranty statement shall be construed to limit any rights or remedies otherwise available under this Contract for breach of warranty.

H. **Workmanship Warranty** Contractor warrants that all components or deliverables specified and furnished by or through Contractor under the Project Definition/Work Order meet the completion criteria set forth in the Project Definition/Work Order and any subsequent statement(s) of work, and that services will be provided in a workmanlike manner in accordance with industry standards.

I. **Survival of Warranties** All warranties contained in this Contract shall survive the termination of this Contract.

63. LEGAL COMPLIANCE Contractor represents and warrants that it shall secure all notices and comply with all laws, ordinances, rules and regulations of any governmental entity in conjunction with the performance of obligations under the Contract. Prior to award and during the Contract term and any renewals thereof, Contractor must establish to the satisfaction of the Director that it meets or exceeds all requirements of the Bid and Contract and any applicable laws, including but not limited to, permits, licensing, and shall provide such proof as required by the Director. Failure to comply or failure to provide proof may constitute grounds for the Director to cancel or suspend the Contract, in whole or in part, or to take any other action deemed necessary by the Director. Contractor also agrees to disclose information and provide affirmations and certifications to comply with the New York State Finance Law.

64. COMPLIANCE WITH SECTIONS 139a AND 139b OF THE NEW YORK STATE FINANCE LAW

The Contractor hereby agrees to the provisions of Sections 139a and 139b of the New York State Finance Law which require that upon the refusal of a person, when called before a grand jury, head of a State department, temporary State commission or other State agency, or the organized crime task force in the Department of Law, head of a Municipal Department or other Municipal Agency, which is empowered to compel the attendance of witnesses and examine them under oath, to testify in an investigation, concerning any transaction or Contract had with the State, any political subdivision thereof, a public authority or with any public department, agency or official of the State or of any political subdivision thereof or of a public authority, to sign a waiver of immunity against subsequent criminal prosecution or to answer any relevant question concerning such transaction or contract.

A. Such person, and any firm, partnership or corporation of which he is a member, partner, director or officer shall be disqualified from thereafter selling to or submitting bids to or receiving awards from or entering into any Contracts with the Authority or any public department, agency or official thereof, for goods, work or services, for a period of five years after such refusal; and

B. Any and all Contracts made with the Authority or any public department, agency or official thereof, since the effective date of this law, by such person, and by any firm, partnership or corporation of which he is a member, partner, director or officer may be canceled or terminated by the Authority without incurring any penalty or damages on account of such cancellation or termination, but any moneys owing, by the Authority for goods delivered or work done prior to the cancellation or termination shall be paid.

65. EQUAL EMPLOYMENT OPPORTUNITY

In accordance with the provisions of Section 220-E of the Labor Law, the Bidder agrees as follows:

A. The Contractor shall comply with all Federal, State and local statutory and constitutional anti-discrimination provisions.

B. That in the hiring of employees for the performance under this Contract or any sub-contract hereunder, no Contractor, sub-contractor, nor any person acting on behalf of such Contractor or subcontractor, shall by reason of race, creed, color, national origin, sex, age, disability, marital status, or military status discriminate against any citizen of the State of New York who is qualified and available to perform the work to which the employment relates under this Contract;

C. That the Authority may deduct from the amount payable to the Contractor under this Contract a penalty of up to fifty dollars (\$50.00) for each person for each calendar day during which such person was discriminated against or intimidated in violation of the provisions of the Contract; and

D. That this Contract may be cancelled or terminated by the Authority, and all monies due, or to become due, hereunder may be forfeited for a second or any subsequent violation of the terms or conditions of the Contract.

E. The Contract shall be void unless Section 222 of the Labor Law, Sections 291 through 299 of the Executive Law and the Civil Rights Law are complied with. The Contractor will also comply with all findings and requests of the State Division of Human Rights.

66. INSURANCE The Contractor agrees to procure and maintain (A) Workers Compensation Insurance as required by the Laws of the State of New York, or proof that Contractor is not required to secure same, as evidenced by certificates or affidavits approved by the State Workers' Compensation Board pursuant to State Workers' Compensation Law § 57 (2); (B) Disability benefits insurance or proof that the Contractor is not required to secure same, as evidenced by certificates or affidavits approved by the State Workers' Compensation Board pursuant to State Workers' Compensation Law 220 (2); (C) Commercial General Liability Insurance (with completed operations, plus X.C.U. when applicable) with a minimum combined single limit (bodily injury/property damage) of Two Million Dollars (\$2,000,000); and (d) Automobile Liability Insurance in the amount specified on the Authority of North Hempstead Insurance Certificate.

Said policies identified in subparagraphs (C) and (D) shall contain assurance of the existence of contractual coverage defending, indemnifying, and holding harmless the Authority, and its employees, agents, and representatives from any and all loss and/or damage arising out of the performance of this Contract, and shall name the Indemnitees as additional insureds thereunder.

The Contractor's Additional Insurance shall be primary and fully exhausted in all circumstances prior to the Authority's own insurance being utilized. Said contractual coverage shall be absolute and not dependent upon any question of the negligence of the Contractor (and its employees, agents, and except, however, that the Contractor shall not be held liable for an occurrence that results solely from the negligence of the Authority).

The above insurance is to be with New York State admitted insurance carriers holding an "A" rating from AM Best Company or its equivalent. The Contractor is required to give the Authority thirty (30) days advance written notice of termination, expiration or cancellation of any insurance coverage required hereunder.

67. INDEMNIFICATION

A. To the fullest extent permitted by law, the Contractor:

(i) shall be solely responsible for and shall indemnify and hold harmless the: Authority and its officers, employees, agents and servants (the "Indemnified Parties") from and against any and all liabilities, all claims, suits, actions, damages and costs, expenses of every name and description (including, without limitation, attorneys' fees and disbursements) and damages ("Losses"), arising out of or in connection with any acts or omissions of the Contractor or any of its officers, directors, employees, servants, agents or independent contractors taken pursuant to or authorized by the performance of this Contract ("Contractor Agents") or from any defective condition of the materials furnished it or supplied or contemplated to be furnished or supplied under this Contract regardless of whether due to negligence, fault, or default, including Losses in connection with any threatened investigation, litigation or other proceeding or preparing a defense to or prosecuting the same, except, however, that the Contractor shall not be held liable when an occurrence results solely from the negligence of the Authority;

(ii) shall, upon the Authority's demand and at the Authority's direction, promptly and diligently defend, at the Contractor's sole own risk and expense, any and all suits, actions, or proceedings which may be brought or instituted against one or more Indemnified Parties and the Contractor shall pay and satisfy any judgment, decree, loss or settlement in connection therewith; and

(iii) shall, and shall cause the Contractor Agents to, cooperate with the Authority in connection with the investigation, defense or prosecution of any action, suit or proceeding arising out of or in connection with this Contract.

(B) The obligations of the Contractor pursuant to Section 67(a) hereof shall not be limited by reason of enumeration of any insurance coverage provided under this Contract.

(C) Nothing in this Section 65 or elsewhere in this Contract shall create or give to third parties any claim or right of action against the Authority beyond that which legally exist regardless of the provisions of this Contract.

(D) The provisions of this Section shall survive the termination of this Contract.

68. EXECUTORY UNDERSTANDING Notwithstanding any other provision of this procurement or the resulting Contract or Purchase Order, the Authority shall have no liability to any Person beyond funds appropriated or otherwise lawfully available for this Contract; and unless (A) all relevant and required Authority approvals have been obtained, including, if required, approval by the Authority Board, and (B) the Contract or Purchase Order has been executed by an authorized representative of the Authority

69. PARTICIPATION BY POLITICAL SUBDIVISIONS:

Under New York General Municipal Law Section 103(16), any contract awarded under this bid (hereinafter, the "Contract") shall be made available to all other governmental entities in New York State. It is understood that the extension of the Contract to such other governmental entities is at the discretion of the Bidder and that the Bidder is not bound, by virtue of such contract, to any contract or agreement other than the Contract. All purchases or other orders made by another governmental entity will be placed by and be the responsibility of such governmental entity. Such governmental entity shall be billed by and make payment to the Bidder directly, with no involvement of the Authority of North Hempstead. The Bidder and any governmental entity using the Contract understands and agrees that sole responsibility with regard to the performance of any work for another governmental entity and all terms and conditions of the Contract (including, but not limited to, payment), shall be assumed by the Bidder and such governmental entity and not by the Authority of North Hempstead. In the event of a breach in the performance of any such work and any and all terms and conditions of the Contract (including, but not limited to, payment) by the Bidder or such governmental entity, the Authority of North Hempstead specifically and expressly disclaims any liability for such breach. The Bidder and any governmental entity utilizing the Contract guarantees to the Authority of North Hempstead that the Bidder shall not hold the Authority of North Hempstead liable for any breach by another governmental entity in the performance of any provision of the Contract, for the payment of any amounts owed by such governmental entity or for any other matter associated with another governmental entity's use of the Contract. The Bidder and any governmental entity using the Contract shall hold the Authority of North Hempstead, its officers, directors, employees, contractors and agents harmless from any liability that may be or is imposed by the failure of the Bidder or such governmental entity to perform in accordance with its obligations, covenants and terms and conditions of the Contract.

BIDDER'S QUALIFICATION STATEMENT

INSTRUCTIONS:

The Bidder's Qualifications Statement Consists of the Following Documents:

1. Statement of Understanding;
2. Disclosure Form;
3. Noncollusive Bidding Certification;
4. Certification of Insurance (*to be completed by an authorized insurance agent*); and
5. Acknowledgement of Receipt of Addenda Form; and
6. Debarment and Suspension Certificate
7. Local Business Certification

Please complete **ALL SEVEN** forms and submit with the Bid/Proposal.

THE AUTHORITY RETAINS THE ABSOLUTE RIGHT TO REJECT ANY BID/PROPOSAL THAT FAILS TO INCLUDE COMPLETE AND ACCURATE ORIGINALS OF ALL FOUR FORMS INCLUDING ALL APPROPRIATE ACKNOWLEDGMENT(S) AND BEARING THE SIGNATURE OF A NOTARY PUBLIC.

STATEMENT OF UNDERSTANDING

By signing in the space provided below, the undersigned certifies, under penalty of perjury, as follows:

1. I am duly authorized to submit this Bid/Proposal on behalf of the below listed sole proprietorship/company/partnership/corporation.
2. That he/she has read and understands all terms and conditions pursuant to this bid, including but not limited to the Bid Documents, Bid Specifications, General Conditions, and bid prices hereto.
3. That he/she has the capacity to and will abide by all terms and conditions pursuant to this bid, including but not limited to the Bid Documents, Bid Specifications, General Conditions, and bid prices hereto.
4. That he/she agrees to accept payment in accordance with the requirements of the Bid Documents, Bid Specifications, General Conditions, and bid prices hereto; and
5. That **DELIVERY** to the destination stated in the Bid Documents will be made within 30 days after the receipt of the order.
6. That he/she will, if his/her Bid/Proposal is accepted, enter into a Contract with the Town of North Hempstead Solid Waste management Authority pursuant to the terms and conditions set forth in the Bid Documents, Bid Specifications, General Conditions, Terms and Conditions and bid prices hereto.
7. That he/she certified that his/her sole proprietorship/company/partnership/corporation will carry all types of insurance specified in the contract.
8. Is the response that you are providing compliant with the instructions set forth in this solicitation for bids?

Yes No

The undersigned further stipulates that the information in this Proposal is, to the best of its knowledge, true and accurate.

Signature

Name of Bidder

Title of Person Signing

Sworn to and subscribed on
this _____ day of _____, 20____

(Notary Public)

DISCLOSURE FORM

The signatory of this questionnaire certifies under oath the truth and correctness of all statements and of all answers to interrogatories hereinafter made.

Provide answers to each of the following and supporting documentation, where necessary. If there is nothing to disclose, please respond N/A. DO NOT FORGET TO INCLUDE ADDITIONAL DOCUMENTATION IN RESPONSE TO QUESTION 7.

1. **Adverse Equal Opportunity Determinations:** Identify all adverse determinations against your Company/Corporation/Partnership, or its employees or persons acting on its behalf, with respect to actions, proceedings, claims or complaints concerning violations of federal, state or municipal equal opportunity laws or regulations.

2. **Convictions and Unscrupulous Practice:** Has your Company/Corporation/Partnership, or any of its employees present or past, or anyone acting on its behalf, ever been cited for unscrupulous practice, or been convicted of any crime or offense arising directly or indirectly from the conduct of your Company/Corporation/Partnership's business, or has any of your Company/Corporation/Partnership's officers, director or persons exercising substantial policy discretion ever been convicted of any crime or offense involving business/financial misconduct or fraud? If so, describe the convictions and surrounding circumstances in detail.

3. **Pending or Threatened Actions/Suits:** Describe any past or present action, suit, proceeding or investigation pending or threatened against your Company/Corporation/Partnership including, without limitation, any proceeding known to be contemplated by government authorities, private parties, or current or former clients.

4. **Criminal Misconduct:** Has your Company/Corporation/Partnership, or any of its employees, or anyone acting on its behalf, been indicted or otherwise charged in connection with any criminal matter arising directly or indirectly from the conduct of your Company/Corporation/Partnership's business which is still pending, or has any of the Company/Corporation/Partnership's officers, directors or persons exercising substantial policy discretion been indicted or otherwise charged in connection with any criminal matter involving business or financial misconduct or fraud which is still pending? If so, describe the indictments or charges and surrounding circumstances in detail.

5. **Survey Forgery (If applicable):** Has your Company/Corporation/Partnership, or any of its employees present or past, or anyone acting on its behalf, ever signed and sealed surveys for which your Company/Corporation/Partnership has not actively participated in the production thereof; or been investigated by the New York Department of State for such activity? If so, describe the circumstances in detail.

6. **Conflicts of Interest:** disclose any of the following, and describe any procedures your company/Corporation/Partnership has, or would adopt, to assure the Authority that a conflict of interest would not exist in the future):
 - (a) Any material financial relationships that your Company/Corporation/Partnership or any

Company/Corporation/Partnership employee has that may create a conflict of interest or the appearance of a conflict of interest in contracting with or representing the Authority.

(b) Any family relationship that any employee of your Company/Corporation/Partnership has with a member, employee, or official of the Authority or that may create a conflict of interest or the appearance of a conflict of interest in contracting with or representing the Authority.

(c) Any other matter that your Company/Corporation/Partnership believes may create a conflict of interest or the appearance of a conflict of interest in contracting with or representing the Authority.

7. **Financial Disclosure:** Submit with this Disclosure Statement Form, any one of the following three items:

- (a) a financial statement, prepared on an accrual basis, in a form which clearly indicates: Bidder's (1) assets, liabilities and net worth; (2) date of financial statement; and (3) name of firm preparing statement.
- (b) a letter of credit reference from a recognized bank or financial institution; or
- (c) a certified copy of a credit report from a recognized credit bureau, such as Dun and Bradstreet or TRW.

THE AUTHORITY RETAINS THE ABSOLUTE RIGHT TO REJECT ANY BID/PROPOSAL THAT FAILS TO INCLUDE COMPLETE DISCLOSURE STATEMENT FORM.

Dated at _____, this _____ day of _____, 20_____.

(Signature, if Individual)

By: _____
(Signature)

(Seal, if corporation)

Print Name: _____
(Legal Business Name of Company/Partnership/Corporation)

Print Title: _____

[MANDATORY AFFIDAVIT(S) AND ACKNOWLEDGEMENT APPEARS ON FOLLOWING PAGE]

-----**(Affidavit for Individual)**-----

_____ being duly sworn, deposes and says, under penalty of perjury, that: a) _____ he/she is an authorized representative of the Bidder/Proposer; b) he/she has read all statements and answers to this DISCLOSURE STATEMENT FORM, including the attached letter of credit/certified copy of credit report or financial statement submitted pursuant to interrogatory number 7 Financial Disclosure; c) the attached letter of credit/certified copy of credit report or financial statement, taken from his/her books, is a true and accurate statement of his/her financial condition as of the date thereof; and b) all of the foregoing qualification information is true, complete, and accurate.

-----**(Affidavit for Partnership)**-----

_____ being duly sworn, deposes and says, under penalty of perjury, that: a) he/she is a member of the partnership of _____, b) he/she has read all statements and answers this DISCLOSURE STATEMENT FORM, including the attached letter of credit/certified copy of credit report or financial statement submitted pursuant to interrogatory number 7 Financial Disclosure; c) he/she is familiar with the books of said partnership showing its financial condition; c) the attached letter of credit/certified copy of credit report or financial statement, taken from the books of said partnership, is a true and accurate statement of the financial condition of the partnership as of the date thereof; and d) all of the foregoing qualification information is true, complete and accurate.

-----**(Affidavit for Corporation)**-----

_____ being duly sworn, deposes and says, under penalty of perjury, that: a) he/she is _____ of _____ (Full Legal Name of Corporation); b) he/she has read all statements and answers this DISCLOSURE STATEMENT FORM, including the attached letter of credit/certified copy of credit report or financial statement submitted pursuant to interrogatory number 7 Financial Disclosure; c) he/she is familiar with the books of said corporation showing its financial condition; c) the attached letter of credit/certified copy of credit report or financial statement, taken from the books of said corporation, is a true and accurate statement of the financial condition of said corporation as of the date thereof; and d) that all of the foregoing qualification information is true, complete and accurate.

-----**(Acknowledgement)**-----

_____ being duly sworn, deposes and says, under penalty of perjury, that he/she is _____ of _____ (Name of Bidder) that he/she is duly authorized to make the foregoing affidavit and that he/she makes it on behalf of () himself/herself: () said partnership; () said corporation.

Sworn to before me this _____ day of _____, 20_____, in the County of _____, State of _____.

(Notary Public)

My Director expires: _____

NONCOLLUSIVE BIDDING CERTIFICATION

By submission of this bid, each bidder and each person signing on behalf of any bidder certifies, and in the case of a joint bid each party thereto certifies as to its own organization, under penalty of perjury, that to the best of knowledge and belief:

- (1) The prices in this bid have been arrived at independently without collusion, consultation, communication, or agreement, for the purpose of restricting competition, as to any matter relating to such prices with any other bidder or with any competitor;
- (2) Unless otherwise required by law, the prices which have been quoted in this bid have not been knowingly disclosed by the bidder and will not knowingly be disclosed by the bidder prior to opening, directly or indirectly, to any other bidder or to any competitor; and
- (3) No attempt has been made or will be made by the bidder to induce any other person, partnership or corporation to submit or not to submit a bid for the purpose of restricting competition.

I, hereby certify under the penalties of perjury that the foregoing statement is true.

By: _____ Bidder's Signature	_____ Date
_____ Print Name	_____ Title
_____ Legal Name of Individual or Business Name of Company/Partnership/Corporation	_____ Bidder's Federal Tax Identification # (Do Not Use SS#)
_____ Address	_____ Email Address

[MANDATORY ACKNOWLEDGEMENT APPEARS ON FOLLOWING PAGE]

-----**(Acknowledgement for Individual)**-----

STATE OF)
 ss.:
COUNTY OF)

On _____, 20__ before me personally came _____ to me known, and known to me to be the individual(s) described in, and who executed the foregoing NONCOLLUSIVE BIDDING CERTIFICATION, and duly acknowledged to me that s/he executed the same.

(Notary Public)

My commission expires: _____

-----**(Acknowledgement for Partnership)**-----

STATE OF)
 ss.:
COUNTY OF)

On _____, 20__ before me personally came _____ to me known, who, by me duly sworn, did depose and say that deponent resides at _____; that deponent is a member of the partnership described in and which executed the foregoing NONCOLLUSIVE BIDDING CERTIFICATION; deponent is authorized to sign the foregoing NONCOLLUSIVE BIDDING CERTIFICATION.

(Notary Public)

My commission expires: _____

-----**(Acknowledgement for Corporation)**-----

STATE OF)
 ss.:
COUNTY OF)

On _____, 20__ before me personally came _____ to me known, who, by me duly sworn, did depose and say that deponent resides at _____ that deponent is the _____ of the corporation described in, and which executed the foregoing NONCOLLUSIVE BIDDING CERTIFICATION, that deponent knows the seal of the corporation, that the seal affixed to the NONCOLLUSIVE BIDDING CERTIFICATION, is the corporate seal, that its was affixed by order of the board of _____ of the corporation; and that deponent signed deponent's name by like order.

(Notary Public)

My commission expires: _____

INSURANCE CERTIFICATION

TO BE COMPLETED BY AN AUTHORIZED INSURANCE AGENT

INSTRUCTIONS:

Please complete this Insurance Certification and attach copies of proof of insurance as follows:

- (a) **Commercial General Liability/Automobile Liability:** ACCORD-25 FORM.
- (b) **Worker's Compensation:** Certificates or affidavits approved by the State Workers' Compensation Board pursuant to State Workers' Compensation Law § 57 (2) evidencing proof of workers' compensation insurance *or* proof of Bidder not being required to secure same.
- (c) **Disability Benefits Insurance:** Certificates or affidavits approved by the State Workers' Compensation Board pursuant to State Workers' Compensation Law § 220 evidencing proof of disability benefits insurance *or* proof of Bidder not being required to secure same.

This form and all supporting documentation must be submitted with this Bid/Proposal even if said information is on-file with the Authority in connection with another bid, project or contract.

(Name and Address of Bidder)

Name of Bid: _____

Bid Number: _____

(1) Commercial General Liability with completed operations (plus X.C.U. when applicable), to which the Authority of North Hempstead has been added as additional insured, and Automobile Liability: \$ 2,000,000.00 Combined single limit (bodily and personal injury/property damage).

Insurance Carrier (Commercial General Liability): _____

Policy Number(s): _____

(2) Worker's Compensation:

Insurance Carrier: _____ Policy Number(s): _____

(3) The above insurance is effective with New York State admitted insurance companies, and is A rated or equivalent to A rated.

(4) Policy cancellation or non-renewal shall be effective only upon thirty (30) days prior notice by certified mail to:

***Authority of North Hempstead, Office of the Authority Attorney, 220 Plandome Road, P.O.B. 3000,
Manhasset, New York 11030***

Authorized Insurance Agent's Signature and Title:

Name, Insurance Affiliation and Address:

Dated

ACKNOWLEDGEMENT OF RECEIPT OF ADDENDA FORM

The bidder hereby acknowledges that he/she has received and that he/she has considered in the preparation of his/her bids, all requirements in the following Addenda to this Bid/Proposal/Contract:

Note: This acknowledgement shall be signed by the person executing the Statement of Understanding.
Insert additional pages, as necessary.

ADDENDUM NUMBER	DATE OF ADDENDUM	ACKNOWLEDGEMENT

<input type="checkbox"/> <u>NO ADDENDUM</u> WAS RECEIVED IN CONNECTION WITH THIS BID/PROPOSAL/CONTRACT. ACKNOWLEDGEMENT: _____
--

IMPORTANT NOTICE:

THIS FORM MUST BE COMPLETED AND SUBMITTED BY ALL BIDDERS. IF NO ADDENDA ARE RECEIVED, CHECK THE "NO ADDENDUM" BOX ABOVE AND SIGN THE ACKNOWLEDGEMENT.

THE AUTHORITY RETAINS THE ABSOLUTE RIGHT TO REJECT AND BID/PROPOSAL THAT FAILS TO INCLUDE THIS ACKNOWLEDGEMENT OF RECEIPT OF ADDENDA FORM

Debarment and Suspension Certification

The Bidder/Offeror certifies to the best of his or her knowledge and belief, that:

By submitting a bid/proposal under this solicitation, the bidder or offeror certifies that at the time the bidder or offeror submits its proposal that neither it nor its principals are presently debarred or suspended by any Federal department or agency from participation in this transaction.

Name of Contractor: _____

Authorized Representative Name: _____

Signature of Authorized Representative: _____

Sworn to before this this _____

Day of _____, 2020

Notary Public

LOCAL BUSINESS PREFERENCE CERTIFICATION FORM

ALL INFORMATION MUST BE PROVIDED

A 5% Preference for Local Businesses (hereinafter, "Preference") may be available for this procurement. To qualify, an Offeror **MUST** complete and submit this Preference Certification Form **WITH ITS OFFER, BID OR PROPOSAL**.

If a Proposal is received without this Preference Certification Form and any required documentation attached, completed, signed and certified, or if this Preference Certification Form is received without the required information, the preference shall not be applied.

LOCAL BUSINESS PREFERENCE

To qualify for the local business preference, the business must:

1. be physically located within the geographical boundaries of the County of Nassau (the "County"); and
2. such presence must have existed for at least a year, established by ownership or lease of premises that includes an operational office for conducting business or selling and/or manufacturing supplies, materials or equipment; and
3. the business must employ a minimum of two (2) full time employees in the County.

In the case of a two-party joint venture both entities must meet the pertinent test for a Local Business set forth above. In the case of joint venture with more than two parties at least a majority of the entities must meet the pertinent test for a Local Business set forth above.

CERTIFICATION

The Preference Certification Form must include a physical location - **NOT** a post office box or other postal address.

PREFERENCE CERTIFICATION FORM MUST BE COMPLETED BY PRINCIPAL OFFEROR. This Preference Certification Form must be completed for the Principal Offeror, or one of the Principal Offerors if the Offeror is a joint venture or partnership, or by an individual authorized to sign for the Offeror. Subcontractors of the Offeror shall not be used to qualify a Proposal for a preference and should not complete or submit the Form.

The total percentage of all preferences awarded shall not exceed ten percent (10%).

ADDITIONAL DOCUMENTATION. If requested, a business shall provide, within three (3) working days of receipt of the request, documentation to substantiate the information provided on the Preference Certification Form. The Director of Procurement shall determine the sufficiency of such documentation.

NO PREFERENCES SHALL BE APPLIED IF THE PROCUREMENT IS SUBJECT TO GENERAL MUNICIPAL LAW 103, IF FEDERAL FUNDS ARE USED OR IF OTHERWISE INAPPLICABLE TO THIS PROCUREMENT.

TOWN OF NORTH HEMPSTEAD
LOCAL BUSINESS CERTIFICATION

I certify my company meets the following qualifications to be eligible for the local business preference:

1. the business is physically located within the geographical boundaries of the County of Nassau (the “County”); and
2. the business has been physically located in the County for at least a year, established by ownership or lease of premises that includes an operational office for conducting business or selling and/or manufacturing supplies, materials or equipment,
3. the business employs a minimum of two (2) full time employees in the County.

Name of Contractor: _____

Address _____

Authorized Representative Name: _____

Signature of Authorized Representative: _____

Sworn to before this this _____ Day of _____, 2020

Notary Public

Exhibit A

PRODUCT SPECIFICATIONS

CPG 95 & 125 JD T4F

Mobile Generator



Standard Scope of Supply

The Chicago Pneumatic **CPG 95 & 125 JD T4F** generators are prime power, multi-voltage, sound attenuated, mobile generators. They are powered by an John Deere Tier 4 Final, liquid-cooled, four cylinder diesel engine.

The units consist of an alternator, diesel engine, cooling system, electrical distribution and control systems - all enclosed within a sound attenuated enclosure fabricated from powder coated steel with zinc rich primer. 1000 hr salt spray teste.

A broad range of undercarriage formats and options are available.

Special attention has been given to the overall product quality, user friendliness, ease of serviceability, and economical operation to ensure best in class total cost of ownership.

Available Models

CPG 95 & 125 JD T4F

Multiple voltage – 95-125 kVA prime power – John Deere engine

Standard Features

- Compact, sound attenuated, corrosion resistant enclosure with single point lifting and 110% fluid containment
- Available as a skid mounted unit with forklift pockets, or on a single axle trailer
- Heavy Duty alternator with AREP excitation and marine grade protection
- “DeepSea” controller
- Single side servicing with long run filters and 500 hour service intervals
- Extremely reliable and durable John Deere 4045 engine with DOC & SCR after-treatment and limited 5 year limited warranty
- Identical enclosures and maintenance points between both models
- Emergency Stop
- Remote Start / Stop

Benefits

- Extremely durable and environmentally sensitive, designed to be used for everything from the oil patch to special event power
- Versatility, giving you the flexibility to match your machine to the correct application
- Start-up power for the most demanding sites with 300% over load starting capabilities
- Reliable and intuitive controls for ease of use and diagnostic capabilities
- Heavy duty oil, air and fuel filters extend the maintenance interval to 500 hours for reduced total cost of ownership
- Reduces maintenance costs with long intervals easy access for mechanics
- Proven engine platform with high reliability, a simple maintenance free Diesel Oxidization Catalyst only after treatment
- Reduces stock of service kits and inventory of parts with rental ROI kept in mind
- External, recessed emergency stop for increased safety
- Allows connection as a critical back-up unit via a 2 wire dry contact connection in the distribution panel

CPG 95 & 125 JD T4F – Product Reference

Technical Data¹

Performance		CPG 95 JD	CPG 125 JD
Frequency	Hz	60	60
Rated prime power 3 ϕ	kW/kVA	76 / 95	100 / 125
Rated standby power 3 ϕ	kW/kVA	83 / 104	101.6 / 127
3 ϕ Power factor		0.8	0.8
3 ϕ Voltage in 480V switch position (series star w/neutral)	V	480Y / 277	480Y / 277
Amp capacity @480V	A	114.3	150.4
3 ϕ Voltage in 240-208V switch position (parallel star w/neutral)	V	240YY / 139-208YY	240YY / 139-208YY
Amp capacity @240V	A	228.5	300.8
Amp capacity @208V	A	263.6	347
Rated prime power 1 ϕ	kW/kVA	54.8 / 54.8	75.6 / 75.6
1 ϕ Power factor		1	1
1 ϕ Voltage in 120-240V switch position (Zig-Zag)	V	240 / 120	240 / 120
Amp Capacity @240V	A	228.5	315.1
Amp Capacity @120V	A	457	630.2
Main breaker - Shunt trip	A	600	600
Power distribution - Terminal board		5 Wire (L1, L2, L3, N, Ground)	5 Wire (L1, L2, L3, N, Ground)
Terminal board connections		Bare Wire Terminals	Bare Wire Terminals
Maximum terminal cable size		350MCM	350MCM
Convenience receptacles		2 x NEMA 5-20R & 2 x 125/250V 50A CS6364	2 x NEMA 5-20R & 2 x 125/250V 50A CS6364
Max. sound pressure level (LPA) @23' @75% Load	dB(A)	69	69.3

Fuel consumption			
Fuel tank capacity	gal	170	170
Fuel consumption at full load (PRP)	gal / h	5.4	7
Fuel autonomy considering 90% of fuel capacity	h	28.3	23.4

Alternator			
Model		Leroy Somer 44.3 S3	Leroy Somer 43.3 S5
Excitation		AREP	AREP
Automatic voltage regulator (+/-0.5%)		Leroy Somer R438	Leroy Somer R438
Insulation		Class H	Class H

CPG 95 & 125 JD T4F – Product Reference

Technical Data¹

Engine			
Model		John Deere 4045 HFG04	John Deere 4045 HFG 06
US EPA Family		HJDXL04.5315	HJDXL0.4.5311
US EPA Tier		Tier 4 Final	Tier 4 Final
Displacement	L	4.5	4.5
Cylinders		4	4
Continuous engine output	hp	122	157
Gross engine power output	hp	133	172
Speed	rpm	1800	1800
Engine control		ECU	ECU
Aspiration		Turbo w/ Intercooler	Turbo w/ Intercooler
Engine oil capacity	US gal	5.4	5.4
Engine coolant capacity	US gal	2.25	2.25
Max. ambient temperature (@Sea Level)	°F	122	122
Min. starting temperature (w/o Cold weather options)	°F	0	0
Minimum starting temperature (w/Cold weather options)	°F	-4	-4
Electrical system (Negative ground)	V	12	12
Engine alternator output	A	90	90
Battery Capacity (Cold Cranking Amps)	A	1100	1100

¹ All ratings are at a reference condition of 0' altitude and 20 °C (72 °F)

² Please see receptacle voltage configuration in Power Distribution section on page #5

³ Engine oil to meet CJ-4 (low ash oil)

⁴ Please see "Derate Table" for altitude and temperature calculations on page #4

⁵ Cold start option comes with 120V block heater and 0W40 synthetic engine oil

⁶ Measured in accordance with ISO 2151 under free field conditions @ 7m distance

⁷ Engine and emissions require the use of Ultra Low Sulfur Diesel in accordance to ASTM-D975 Grade No. 1-D S15 & No.2-D S15

⁸ Based on 90% volume of fuel tank

CPG 95 & 125 JD T4F – Product Reference

Technical Data¹

Dimensions

Trailer Mounted

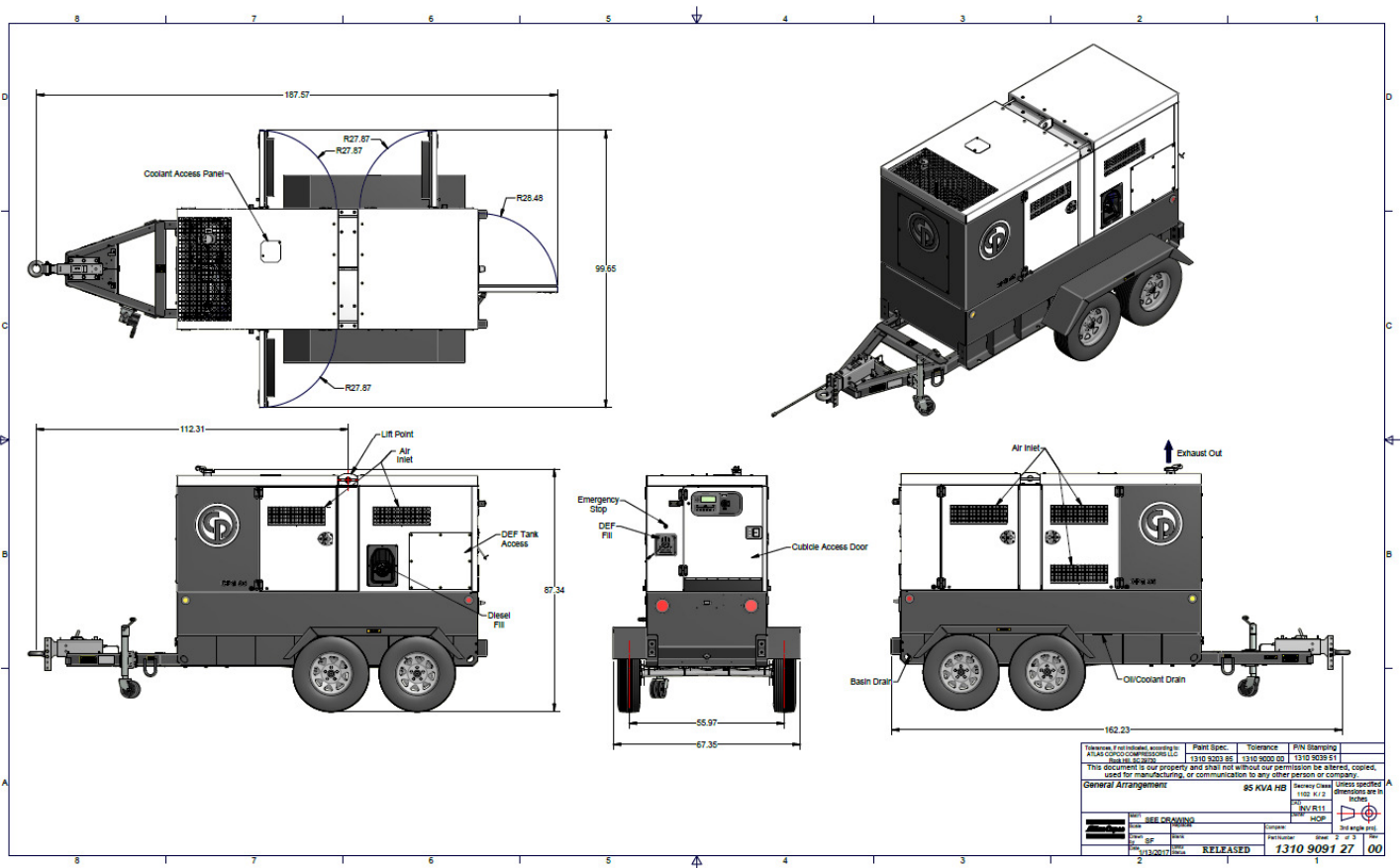

CPG 95 & 125 JD T4F – Product Reference

Technical Data¹

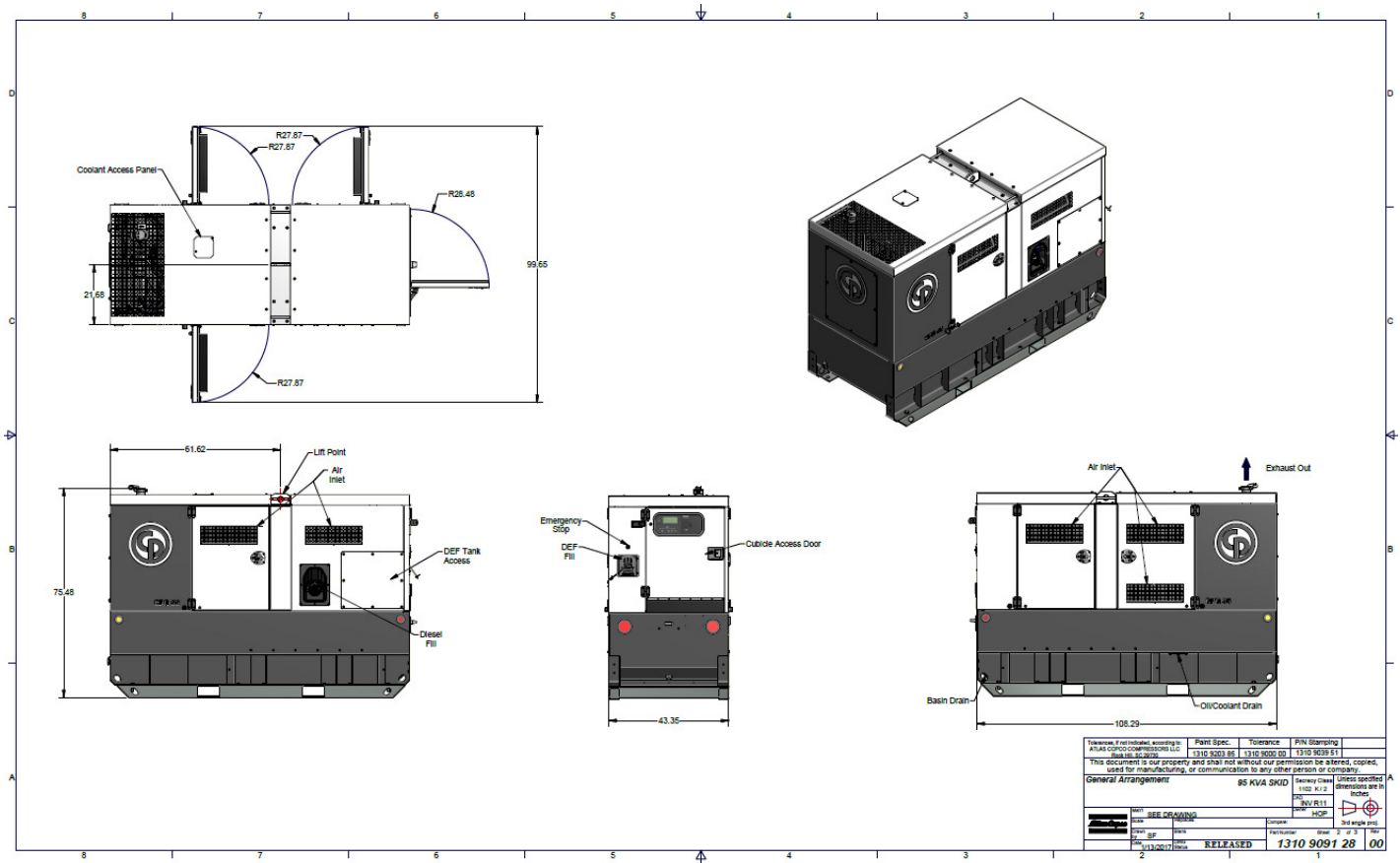

Weight - Wet (ready to operate)

Trailer Mounted
Skid Mounted

Units

lbs (Kg)
lbs (Kg)

CPG 95 JD

6485
TBA

Dimensions

Trailer Mounted (L x W x H)
Skid Mounted (L x W x H)

Inches
Inches

162.4 x 56 x 85.5
108.2 x 43 x 75.5

Weight - Wet (ready to operate)

Trailer Mounted
Skid Mounted

Units

lbs (Kg)
lbs (Kg)

CPG 125 JD

6485
TBA

Dimensions

Trailer Mounted (L x W x H)
Skid Mounted (L x W x H)

Inches
Inches

162.4 x 56 x 85.5
TBA

Principle Data

Alternator

The Leroy Somer LSA alternators are designed for heavy duty continuous applications, with marine winding protection and Leroy Somer's AREP excitation system.

- AREP Excitation for superior motor starting capabilities
- Marine grade (relative humidity >95%) protection
- External multi-voltage selector switch (3 – position)
- 4 pole brushless design with single bearing, Class H insulation and IP23 rating
- Voltage regulation +/- 0.5%
- Full Load acceptance of prime power rating

The AREP system uses 2 independent auxiliary windings located in the main stator to send supply voltage to the AVR:

- The voltage delivered by the first auxiliary winding H1 is proportional to the alternator output voltage (shunt characteristic).
- The voltage delivered by the second auxiliary winding H3 is proportional to the current drawn by the alternator and is a function of the applied load (compound characteristic – boost effect).
- The resulting phase-to-phase voltage supplies power to the AVR.

This power supply to the AVR power circuit is independent of the voltage sensing measured on the alternator output terminals. Therefore, the excitation current delivered by the AVR to the alternator exciter is independent of any voltage distortions (harmonics) due to the load. The AREP system gives the alternator a high overload capacity (load impact or starting electric motors) and a short-circuit capability (300% - 10 s) in order to provide discriminating protection: the alternator with AREP excitation is shorter than the one with PMG excitation. It is particularly suitable for demanding applications.

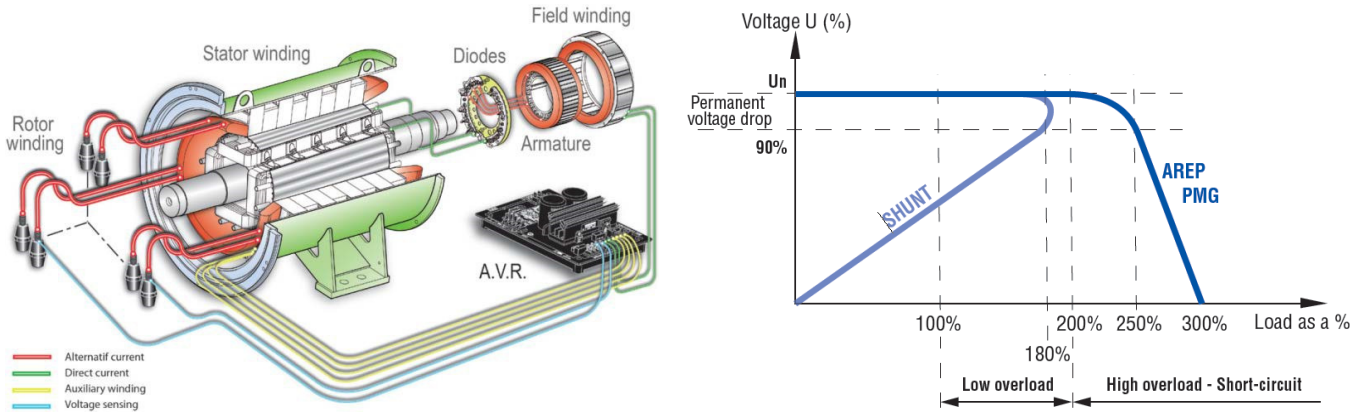

Performance @ Altitude and High Ambient Conditions

When using at altitude and high ambient conditions the engine and alternator will de-rate as per chart below.









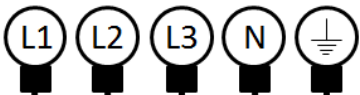

Height m (Feet)	Temperature °C (°F)										
	0 (32)	5 (41)	10 (50)	15 (59)	20 (68)	25 (77)	30 (86)	35 (95)	40 (104)	45 (113)	50 (122)
0	100%	100%	100%	100%	100%	100%	100%	100%	100%	100%	100%
500 (1640)	100%	100%	100%	100%	100%	100%	100%	100%	100%	97%	94%
1000 (3280)	100%	100%	100%	100%	100%	100%	100%	100%	100%	97%	94%
1500 (4921)	100%	100%	100%	100%	100%	100%	100%	99%	97%	94%	91%
2000 (6561)	100%	100%	100%	100%	100%	98%	97%	95%	94%	91%	88%
2500 (8202)	100%	100%	100%	100%	100%	95%	94%	92%	91%	88%	86%
3000 (9842)	100%	100%	100%	100%	100%	91%	90%	88%	87%	84%	82%
3500 (11,482)	100%	100%	100%	100%	94%	88%	84%	81%	80%	78%	77%
4000 (13,123)	75%	75%	75%	75%	75%	75%	75%	75%	75%	75%	75%

Power Distribution

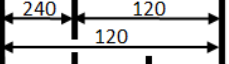
The main power is connected from the alternator through a 3 position voltage selector switch to the main power cubicle. The cubicle incorporates all power distribution, controls, sensing and protection devices.

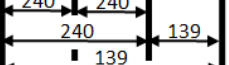
- ✓ 3 position Voltage Selector Switch (VSS)
- ✓ Current transformer x 3 (1 each leg)
- ✓ Single main breaker w/shunt trip
- ✓ Individual breakers for each receptacle
- ✓ Convenience receptacles located on outside of unit for easy access
- ✓ Terminal board for hard wiring
- ✓ Cam-Lock external quick connect (available as option)
- ✓ External emergency stop switch (recessed)
- ✓ Neutral bonded to Ground with a removable bonding link accessible in the control cubicle

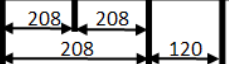
Please refer to the chart below for power distribution and voltages. NOTE: All voltages below are subject to change, depending on set point of “Fine Voltage Adjustment” potentiometer and Voltage Selector Switch.

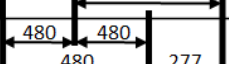
		120V Receptacle NEMA 20-5R	125/250V Receptacle CS6364	Terminal Board
Fine Voltage Adjustment ↓	Voltage Selector Switch Position ↓			
	 240/120V 1Ø	120V	240/120V	
	 240/139V 3Ø	139V	240/139V	
	 240/139V 3Ø	120V	208/120V	
	 480V 3Ø	139V	240/139V	

- All voltages are adjustable with the “Fine Voltage Adjustment” potentiometer located on the control panel. Therefore voltage may be different then what is shown in the above table. All voltages should be verified before connection to the unit.

Controller

The CPG 95 & 125 come equipped with a Deep Sea 7310 control module. This is a fully diagnostic ECU controller with large 3” display, that is intuitive and easy to operate with all functions conveniently at your fingertips. The controller also manages the engine ECU operating system, and a number of safety warnings and shut downs on various parameters (listed below).

The controller is powered by a main On/Off switch located next to unit.

DeepSea 7310 Controller Functionality:

- Home Page (displayed while running, scrolling every 3seconds)
 - ✓ Generator voltage(ph-ph)
- Generator Page
 - ✓ Generator voltage(ph-N)
 - ✓ Generator voltage(ph-ph)
 - ✓ Generator frequency
- Load Page
 - ✓ Generator current (A)
 - ✓ Generator earth current
 - ✓ Generator load (kW)
 - ✓ Generator load (kVA)
 - ✓ Generator power factor
 - ✓ Load ph-N (kVAr)
 - ✓ Generator Load (kVAr)
 - ✓ Generator Load (kWh, kVAh, kVArh)
 - ✓ Generator phase sequence
 - ✓ Dual mutual status
- Event Page
 - ✓ Displays the last 15 events
- Remote Start/Stop
 - ✓ Automatic start stop via 2 wire dry contact connection
- ✓ Operational Buttons
 - ✓ Start button
 - ✓ Stop button
 - ✓ Automatic mode (external remote start)
 - ✓ Up/Down arrows
- ✓ Info Page
 - ✓ Model number
 - ✓ USB identification number
 - ✓ Configured enginetype
 - ✓ Module's date and time
 - ✓ Scheduler setting
- ✓ Engine Page
 - ✓ Engine speed
 - ✓ Oil pressure
 - ✓ Coolant temperature
 - ✓ Engine Battery volts
 - ✓ Run Time
 - ✓ Oil Temperature
 - ✓ Fuel Temperature
 - ✓ Turbo Pressure
 - ✓ Fuel Pressure
 - ✓ Fuel Consumption
 - ✓ Fuel Used
 - ✓ Fuel Level
 - ✓ Auxilliary Sensors
 - ✓ Engine Maintenance Due
 - ✓ Engine ECU Link
 - ✓ DPF Soot Level
- ✓ Engine DTC Page
 - ✓ This page contains any active Diagnostic Trouble Codes that the engine ECU is currently generating. These alarms are conditions detected by the engine ECU and displayed on the DSE controller.



Engine

John Deere 4045

John Deere Tier 4 Final, turbo charged, intercooled, four-cylinder, liquid-cooled diesel engine provides ample power to operate the generator continuously at full-load.

Meets all US EPA, CARB and Environment Canada exhaust legislations with Tier 4 Final compliance. The engine utilizes a Selective Catalytic Reduction (SCR) and Diesel Oxidation Catalyst (DOC) to meet final Tier 4 emissions All functionality of the engine is controlled automatically on the Deep Sea 7310 controller.

The engine has the capability to start the generator at 14°F (-10°C) with standard glow-plug aid.

The 166 gal (628L) fuel tank is sufficiently sized to operate the unit at full-load condition for long run times (see chart on page 2 for specifications).

The engine operates on a 12V negative ground electrical system with a 100A charging alternator. The cooling system is suitably designed for continuous operation in ambient conditions up to 122°F (50°C), with canopy door closed.

Fuel System

A large 170 gal plastic fuel tank provides safe diesel storage while eliminating tank corrosion contaminants from being introduced to your fuel system. With integrated fuel water separator and filter, the system is designed to help maintain clean and trouble free diesel supply to the engine for reliable trouble free operation.

- ✓ Pad-lockable diesel fill cap
- ✓ Fuel / Water separator
- ✓ Inline priming pump (w/ filter)
- ✓ Fuel pre-filter
- ✓ Fuel supply pump (w/ strainer)
- ✓ Fuel level sensor
- ✓ Low fuel shut down feature (programmable level)

Scheduled maintenance

Standard equipped with filters sized and designed to allow 500 hour service intervals under normal operating conditions. Extended time between services reduces down time and total cost of ownership of the unit over its lifetime.

- | | |
|---|--|
| <ul style="list-style-type: none"> • 500 Hour Service Interval: <ul style="list-style-type: none"> ✓ Air filter ✓ Oil filter ✓ Fuel filter ✓ Fuel / water separator | <ul style="list-style-type: none"> • 1000 Hour Service Interval: <ul style="list-style-type: none"> ✓ Air filter ✓ Oil filter ✓ Fuel filter ✓ Fuel / water separator ✓ V-Belt |
|---|--|

NOTE: Site specific operating conditions such as; poor fuel quality and low load profile may require more frequent service intervals.

Enclosure & Frame

The generator enclosure is designed for extreme applications to provide superior performance and reliability.

The enclosure is fabricated from Zink rich Primer which is powder coated for corrosion resistance. The enclosure and frame are fully sealed from the radiator to the back of the unit, providing a true 110% containment of all fluids.

- ✓ Zink rich Primer, powder coated enclosure
- ✓ Heavy duty baseframe
- ✓ 110% fluid containment
- ✓ Larger 166 gal (628L), polyethylene fuel tank
- ✓ Convenient 2" NPT drain at rear of machine to clean out the containment frame
- ✓ Superior level of rain ingress protection and design features
- ✓ Pad-lockable doors and fuel cap
- ✓ Engine fluid plumbed to exterior of frame for ease of service
- ✓ Central lifting point
- ✓ Sound dampening material and design to allow quiet operation at 67 & 66 dB(A) respectively

Undercarriage

The CPG 95 & 125 is available with two undercarriage alternatives, providing utmost flexibility in installation, site handling or towing. Both the skid frame and the trailer mount the same way and can be interchanged for versatility.

- Trailer:
 - ✓ Single axle
 - ✓ Available with hydraulic or electric brakes
 - ✓ DOT/Federal MVSS 49CFR571 approved light package and 7 flat blade RV style plug
 - ✓ Adjustable height pintle hitch (3" lunette)
 - ✓ 15" Rims w/ ST205/75D15 Tires for trailer use
 - ✓ Heavy Duty torsion axle rated at 5,000lbs w/ brakes
 - ✓ Safety chains
 - ✓ Screw jack leveling, with pad foot, 5,000 lbs static capacity
 - ✓ Single point lifting structure
 - ✓ D-Ring Tie down points x4

- Skid mounted:
 - ✓ Sub-frame skid with integrated forklift pockets
 - ✓ Heavy duty design for use in extreme conditions
 - ✓ Frame is ¼" wider than machine to reduce damage from forklifts
 - ✓ Built-in locations for straps or chains to secure the unit for transport
 - ✓ Single point lifting structure

Factory Options Available

- Single axle trailer with hydraulic
- 2" or 2 5/16" ball hitches (shipped loose)
- Trailer stabilizerjacks
- Trailer mounted toolbox
- Cold start kit (120V block heater, 0W40 synthetic engine oil)
- Battery charger (12V, 6A)
- Battery isolation switch (lockable)
- Heavy duty battery (800CCA Optima, Spiralcell AGM, Redtop)
- Inlet shutdown valve
- CSA approval
- External fuel quick connects (3 way valve, located inside of enclosure for spill containment and protection)
- Cam-Lok quick connections (5 x 400A)
- LoJack® (Stolen Vehicle Recovery System)
- Telematics system (DSE Webnet System)

Manufacturing & Environmental Standards

The **CPG 95 & 125 JD T4F** is manufactured following stringent ISO 9001 regulations, and by a fully implemented Environmental Management System fulfilling ISO 14001 requirements.

Attention has been given to ensure minimum negative impact to the environment.

The **CPG 95 & 125 JD T4F** meets all current US EPA, CARB and Environment Canada exhaust and noise emission directives.



Supplied Documentation

The unit is delivered with documentation regarding:

- Hard copies of the Chicago Pneumatic Operators Safety and Instruction Manual, Chicago Pneumatic Parts Book, John Deere Engine Manual and Parts book, in English as well as electronic copies available on request.
- Warranty Registration card for engine and Chicago Pneumatic Generators (Units must be registered upon receipt).

Warranty Coverage

Chicago Pneumatic Generator: Warrantied to be free from defects with regard to material and workmanship for the period of eighteen (18) months from date of shipment from the factory, or twelve (12) months from date of initial startup, whichever occurs first, without limitation of running hours.

John Deere Engine: John Deere Diesel engines are warranted to be free from defects with regard to materials and workmanship for the period of twelve (12) months without limitations in running hours, or twenty-four (24) months prior to the accumulation of 2,000 hours from the date of invoicing from Chicago Pneumatic. John Deere's limited warranty extends to sixty (60) months or 5,000 hours of use, whichever occurs first (some conditions apply*). Unit must be registered directly with John Deere upon receipt to be eligible for warranty. Failure to register warranty upon initial start-up may cause warranty claim delays or rejection of claim by John Deere.

Leroy Somer Alternator: Warrantied to be free from defects with regard to material and workmanship for the period of twenty seven (27) months from date of shipment from the factory, or twenty four (24) months from date of initial startup or 10,000 hours, whichever occurs first.

Extended Warranty Programs: Programs are available; please contact your local sales representative for more info.